



User's handbook on
SOLAR WATER HEATERS



**International Copper
Promotion Council India**
Copper Alliance

Preface



Government of India
Ministry of New and Renewable Energy
UNDP/GEF GLOBAL SOLAR WATER HEATING PROJECT

No.

Date

Dated 2nd January, 2012

The Ministry is implementing a UNDP / GEF Project on "Global Solar Water Heating Market Transformation and Strengthening Initiative" under UNDP's India country programme. The project will contribute to achieve the target under the Jawaharlal Nehru National Solar Mission. One of the important outcomes is the enhanced awareness of the End Users.

As a part of the Key activity for this outcome, a Solar Water Heater Users' Handbook was prepared and widely circulated. The first Edition was received warmly and State Nodal Agencies have expressed their desire to have more copies of the same for circulation to interested entities. The Handbook was commissioned by International Copper Promotion Council (India) in a very user friendly format who are partner in Project.

Solar Water Heaters are now rapidly becoming popular. It is, however, very important that the users understand the product, its shortcomings, its maintenance and how to make best use of the product in the user's environment.

I am pleased to present the reprint of the First Edition.

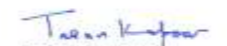
(TARUN KAPOOR)
Joint Secretary, MNRE &
National Project Director

Project Management Unit
UNDP / GEF GSWH PROJECT
Block No. 14, C.G.O Complex, Lodi Road, New Delhi - 110003

Foreword

The use of hot water for bathing and other purposes has become an integral part of modern lifestyles. With the abundant availability of sunlight in our country, even in colder regions, solar water heating is a natural solution. It has been established that the investment in solar water heaters pays itself back through saved electricity costs in 4 to 5 years, and thereafter the hot water becomes available for free over the lifetime of the equipment of more than 15 years. Government subsidized loans are available to finance the equipment costs.

In spite of these facts, the penetration of solar water heaters remains far below potential. Some of the barriers that have been identified, are the lack of organized information to users about the different technologies available, the selection and sizing of equipment, an evaluation of the costs and questions concerning installation, maintenance and trouble-shooting.

It is to address this need that the International Copper Promotion Council (I) is publishing this handbook, as a partner of the Ministry of New & Renewable Energy, Government of India, and the Global Environment Fund, in the Global Solar Water Heater Market Transformation and Strengthening Initiative project.

We hope that users will find this handbook of value.

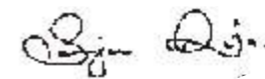

Sanjeev Rajan
CEO, International Copper Promotion Council (India)



Introduction

Solar thermal technologies hold significant promise for India, with high solar insolation of to 4 6.5 kWh/ sq.m /day for an average of 280 sunny days. The solar water heating system is a commercially viable and technologically mature product which has existed in the country for many years. Yet, against a technical potential of 45 million sq. km. of collector area, approximately 6 million sq. km of collector area has been installed. This works out to a little more than 2 sq.m./1000 people as against countries like Israel and Cyprus, which have over 500 sq.m./1000 people.

In order to transform the solar water heating market in India, the Ministry of New and Renewable Energy (MNRE) has joined hands with UNDP/UNEP/GEF Global Solar Water Heating Market Transformation Strengthening Initiative. Under this project, India aims to achieve 20 million sq. m. collector area by 2022. In absence of any intervention, the market was projected to add much less million sq. m. during this period. International Copper Promotion Council (India) is also a partner to this project in India.

The climate of India varies from extremes to moderate, due to its large geographic size and varied topography. The climatic conditions in the northern hills are quite different than that of the southern parts of India, and in the plains also, extreme climatic conditions are common. The use of hot water is common for residential applications in the cooler regions of the country. In urban and semi-urban areas also, hot water use is becoming a part of the lifestyle. In all these areas, water is normally heated up with electricity, which is expensive and not available 24 x 7. Therefore, a solar water heating system can be the suitable alternative to meet the growing hot water requirement in the country, without exerting further demand pressure on the electricity generation capacity in the country. However, in quite a number of cases, solar water heaters had failed to earn appreciation of the users, due to sub-optimal design, inferior product quality, mismatch of technology with the environment and water quality and bad installation practices.

The purpose of this handbook is to provide guidance to customers to study the various aspects while selecting a solar water heater for their hot water requirements and take an informed decision while purchasing a solar water heating system. The book contains the following chapters to help the customers:

- 1) **The general technical specifications a user should look at while selecting a solar water heating system.**
- 2) **The choice of technology for a particular application, keeping in mind the environmental conditions and hot water applications.**
- 3) **How to determine the size of the water heating system for different residential and commercial applications. This chapter also provides a simple mathematical model to decide the approximate size of the solar heating system in residential applications.**
- 4) **The need to look at the various economic factors while evaluating the cost of a solar water heating system.**
- 5) **The different aspects the user needs to look at while having a solar water heating system installed.**
- 6) **Regular and periodic maintenance and the trouble-shooting methods.**
- 7) **Frequently asked questions (FAQs).**
This chapter also has Annexure A and Annexure B, which give the details of:
- 8) **The principles of solar water heating systems.**
- 9) **Illustrations of successful solar water heating systems in residential, commercial and industrial applications in India.**

The rationale of this book is to provide adequate information to potential solar water heater users to help them in selecting the right technology and product for their applications. We hope the book will be useful to such users in procuring the systems and also in getting optimum results from these systems.



Atam Kumar

Independent Consultant
Solar Water Heating Systems,
Delhi

Virender Kumar Gupta

Senior Consultant
International Copper Promotion Council (India),
Mumbai



Acknowledgements

This handbook on solar water heaters is an effort to provide guidance to the users in selecting the right technology and product for hot water applications.

It is the second edition of the Handbook wherein following individuals have contributed significantly with their ideas and suggestions to shape up this handbook. The objectives of this handbook would not have been complete without the active

The Ministry of New & Renewable Energy (MNRE)

- Shri Gireesh B. Pradhan, Secretary
- Shri Tarun Kapoor, Joint Secretary
- Dr. A.K.Singhal - National Project Manager, UNDP/GEF Project
- Dr. Santram - Director
- Dr. S.K.Singh, Director, Solar Energy Center
- Dr. J.P.Singh, Director, Solar Energy Center
- Shri Pankaj Kumar, Dy. National Project Manager, UNDP/GEF Project

United Nations Development Programme (UNDP)

- Dr. S. N. Srinivas
- Ms. Chitra Narayanswamy

Copper Development Centre, Europe

- Mr. Nigel Cotton

ICPCI

- Mr.Sanjeev Ranjan
- 



Contents

Table of Contents

- 1. General Technical Specifications of Solar Water Heaters**
- 2. Selection of the Right Technology**
- 3. Sizing of the Solar Water Heater System**
- 4. Cost Evaluation of the Solar Water Heater System**
- 5. Installation of the Solar Water Heater System**
- 6. Maintenance And Trouble-shooting**
- 7. Frequently Asked Questions (FAQs)**
- 8. Annexure A**
- 9. Annexure B**

Chapter 1

General Technical Specifications of Solar Water Heaters

Introduction

India is blessed with abundant solar energy. Solar water heating systems are a technically proven, successful application for the use of this energy. However the market for solar water heaters is not yet developed fully. This informative handbook on solar water heaters has been prepared for the Ministry of New and Renewable Energy (MNRE), to address the concerns of solar water heater system users for different solar water heating applications.

Objective

The objective of the handbook is to help users make the right and informed decision while purchasing a solar water heater.

This handbook also intends to convey a better understanding of solar water heating systems and to provide basic guidance for the periodic maintenance and trouble-shooting mechanisms, for reliable and durable service from the solar water heaters.

Guidelines on technical specifications

Scope: These guidelines on specifications are created for end users of solar water heaters for small residential (up to capacity of 300 litres/day) and large residential, commercial and industrial applications

Site and service conditions: India is a tropical country. The climatic conditions and water quality vary from place to place. The solar water heating systems have to meet the requirements of ambient temperature variations from -5°C to 40°C ; altitudes ranging from 0 meters to 5000 meters above mean sea level, relative humidity ranging from 30% to almost 100% and wind velocity ranging from 2 meters/sec to 7 meters/sec, with the possibility of hail storms in many places.

Reference standards: The Ministry of New and Renewable Energy (MNRE) has helped in the formulation of Indian Standards for Solar Flat Plate collectors by BIS. These standards are recognized and accepted nationally.

Test, Inspection and Test report: There are mainly two test reports, namely type test report and routine test report.

The type test certificate has data pertaining to design, raw material, workmanship and quality control during the manufacturing process. It certifies that all the critical parameters pertaining to overall system efficiency are well within the range set by the standard.

The routine test certificate provides all the data that needs to be verified before the system is dispatched from the manufacturer's factory to the site of installation. In case of larger installations, the users may also visit the manufacturer's factory to inspect the

quality standards followed during manufacturing and witness the routine tests performed by the manufacturer before dispatch of systems.

Drawings and instructions: All drawings must be furnished to illustrate the significant components of the solar water heater system, with installation instructions along with necessary drawings, plumbing instructions with necessary drawings, safety instructions with drawings at the time of installation, and routine maintenance instructions.

Depending on specific site conditions, it is necessary to provide the user with a set of special instructions in an explicit and easy to assimilate format, for reliable and smooth operation of the solar water heater system.

Ratings and features: The capacity of the system and all major characteristics of the system must be specified on the name plate. The system must also carry a detailed specification of important parameters in the user manual for the customer's reference. A table of suggested details is given below.

Table 1: Ratings and Features of Solar Water Heating Systems

SI No.	Parameters	FPC based systems	ETC based systems
Collector name plate details			
01	Name & Address	Manufacturer's name & address	Manufacturer's name & address
02	Product type and code	FPC – (Product Code)	ETC – (Product Code)
03	Collector area	2 square meters	No. of tubes - 15 or more
04	Absorber materials	Riser and fins with selective coating	Glass with selective coating
05	Collector box	Aluminum / GI/ MS with corrosion protection	
Storage tank name plate details			
01	Name & Address	Manufacturer's name & address	Manufacturer's name & address
02	Product type and code	Vertical / Horizontal – (Product Code)	Horizontal – (Product Code)
03	Capacity	In liters	In liters
04	Construction	Insulated tank with cladding	Insulated tank with cladding
05	Material	Stainless steel grade 304 or better	Stainless steel grade 304 or better
06	Water flow mechanism	Forced / Thermo siphon	Forced / Thermo siphon
07	Insulation	Density XX mm / m ³ , Thickness mm	Density XX mm / m ³ , Thickness mm
08	Heat exchanger	Yes / No	Yes / No
09	Electrical back up	XX KW booster heater	XX KW booster heater
The following table gives the important technical specifications for the user to specify at the time of obtaining quotations and before taking the purchase decisions.			
SI No.	Parameters	FPC based systems	ETC based systems
Collector specifications			
01	Absorber material (Fins)	As per BIS standard IS – 12933, 2003	
02	Absorber coating		
03	Riser		
04	Header		
05	Bonding between riser & header		
06	Bonding between fins & tubes		
07	Back insulations		
08	Side insulations		
09	Collector box		
10	Collector bottom sheet		
11	Collector stand		
12	Glazing		
13	Retainer angle of glass		
14	Beading of glass		
15	Absorber area		
16	Collector tilt		
17	Heat transfer medium		
18	Collector area		
19	Number of fins		
20	Dimensions		

General requirements

It is necessary to have a solar water heating system with the right technology, features and capacity, to ensure a long term reliable and smooth operation of the system. Installation of the solar water heater in the right manner, suitable for the specific site conditions, is very important for the optimal performance of the system.

In case of a large system located on the rooftop of a building, provision of a lightning arrester must be made in case it is not already provided.

The name plates should be easily visible to the installers. Safety instructions must be provided along with the system to ensure installation safety at site.

Additional system requirements

The following additional system-technology features may help in the selection of a solar water heating system with appropriate technology, suitable for the size and site conditions.

Thermo siphon system: For a small application of up to 3000 liters capacity, users may prefer the thermo-siphon system for its simplicity and ease of operation. In such cases, the source of the cold water must be placed at least 7 feet above the terrace level for size up to 500 liters. For larger tank sizes, the height requirement may go up to 10 feet or higher, where the solar water heater system will be installed.

Forced circulation system: For systems of size larger than 3000 liters per day, the customer may choose the forced circulation system. This system may also be used for smaller than 3000 litres/day capacity, where the thermo-siphon system cannot be used due to limitation of height of the cold water tank.

Solar water heater with heat exchanger: In places where the water quality is not suitable for direct use in the solar collector, or in cold regions where the water in the collector may freeze in the night, a solar water heater system with indirect heating is required. Users located in low temperature zones (minimum night temperature of 2° C and below) have to use a solar water heater with indirect heating with antifreeze. If the water pressure of the cold water source is very high (above 3 bar) it will be necessary to use heat exchangers.

For the thermo-siphon system, the heat exchangers shall always be in the hot water storage tank. Whereas the forced flow systems, the heat exchanger maybe located inside the hot water storage tank or outside the tank, depending on the design.

Flat plate collector: A flat plate collector collects solar radiation and converts solar energy into heat for heating water. The flat plate collector should be reliable and durable with a useful life of 15 years or more. The main characteristics of this collector should be:

- Resistance to environmental conditions (marine environment, rain, dust, hail etc.)
- Resistance to large variations in temperature
- Resistance to leakage from any part of the system
- Stable and durable
- Easy to install
- Efficient in energy conversion

These characteristics are required to be fulfilled as per BIS standard IS-12933-2003. The main components of the flat plate collector which are important to meet the above characteristics.

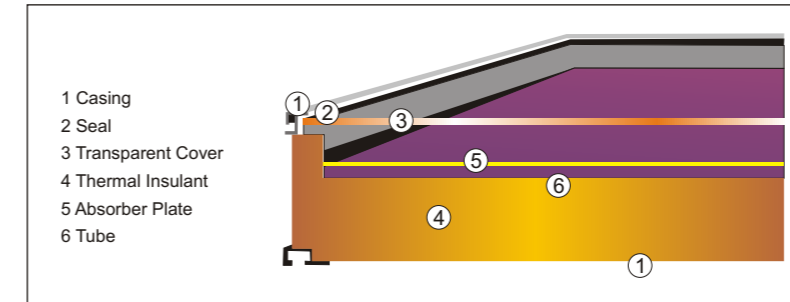

Fig 1: Flat plate solar collector - Cutaway view

Casing

The casing contains all the components of the collector and protects them from environmental impact. The casing also makes the collector sturdy and stable. The material used for the casing must be resistant to corrosion.

Seal

The seal is made out of elastic material to prevent leakage and ingress of rain water into the collector. The sealing material must withstand high temperature variations and ultraviolet (UV) radiation, to ensure a long life of 15 years or more.

Transparent cover

The transparent cover should be made of toughened glass with high transmission co-efficient (close to 1). This also protects the components inside the collector from environmental impact.

Thermal insulation

The thermal insulation reduces undesirable heat loss from the back and sides of the collector area. The insulation must also be able to withstand the maximum temperature of the absorber plate.

Absorber plate

The absorber plate absorbs the solar energy and converts it into heat energy in the fluid. The absorber is made out of high conductivity material like copper with a selective coating on it for maximum absorption of solar radiation and minimum emission of infrared radiation.

Tube

The fluid that flows through the collector shall collect the heat for useful applications. The transfer of heat shall take place mainly through the conduction and convection process. Therefore, the tubes should be made out of a high conductivity material like copper.

Evacuated tube collector: The evacuated tube collector (ETC) uses solar energy to heat the fluid inside the tube through absorption of radiation, but reduces the loss of heat to the atmosphere due to the vacuum inside the tube. An evacuated tube has different sub-categories based on the material used with proper maintenance and application requirement. The life of the evacuated tube varies from 5 years to 15 years. The main characteristics of the evacuated tube collector should be:

- The capability to endure environmental conditions (rain, dust, etc. and in some cases marine environment)
- The capability of enduring large variations in temperature
- Resistance to leakage from any part of the system
- Stability and durability
- Easy to install
- Efficient in energy conversion

These characteristics are required to be fulfilled by the collector in the existing MNRE standard. The main components of the ETC should meet the above characteristics.

Glass tube

The glass tube is formed by fusing two co-axial glass tubes at both the ends. The air between the two glass tubes is evacuated to create vacuum, which works as an insulation. The outer surface of the inner tube in the ETC forms the collector area.

Absorber coating

An absorber coating shall be selectively applied on the outer walls of the inner tube to absorb the solar radiation to collect energy and to convert light energy into heat energy. The selective absorption coating has an absorption co-efficient of 0.94 or more and emissivity of 0.12 or less. The coating should not deteriorate during the life of the system.

Gasket

The gasket between the tank and the ETC or between the manifold and the ETC is crucial for the trouble-free performance of the water heating system with the ETC. The gasket should be capable of sustaining the temperature and pressure encountered. This should fit tightly above the tube to avoid any leakage. The life of the gasket should be equal to the life of the entire system.



Chapter 2

Selection of the Right Technology

Introduction

Solar water heaters are available in two different technologies: the Flat Plate Collector technology (FPC) and the Evacuated Tube Collector technology (ETC). Both FPC and ETC products are available, in India. ETC systems with heat pipes are also available but these are not used commonly. The customer can choose the right technology for his specific hot water requirement and as per site limitations. Problems have been observed at times, due to the selection of unsuitable technology.

Objective

The objective of this chapter is to create familiarity with the technology of solar water heating systems to enable the user to make an informed choice of a solar water heating system as per location, environment and requirement of hot water.

Selection of the right technology

The performance of an ETC and FPC based solar water heater systems varies with the location, season and many other external factors. A report received from the Beijing Solar Energy Institute confirms the statement.

Ambient air temperature: The ambient (outdoor atmospheric) air temperatures during night and day play an important role in the selection of the right technology. In cold climatic conditions, where the ambient temperature reaches the freezing temperature of water, the performance of a heat pipe based ETC based system is better as compared to the FPC based system. Similarly, the direct heating of water is not advisable in such conditions. It is recommended that the customer should opt for a heat pipe based ETC system or FPC based system with a heat exchanger, if the ambient temperature can go below 2° C. The following graph illustrates the above-mentioned fact.

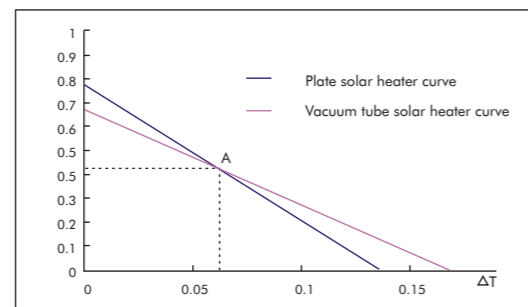

Graph 1

In the figure, the Y axis represents the efficiency of the solar collector and the X axis represents the ratio of temperature difference to the solar radiation. Therefore, $\Delta T = (T_i - T_a) / G$

Where T_i = Inlet temperature of the fluid inside the solar collector, in C0
 T_a = Temperature of outdoor air, in C0
 G = Solar radiation on the collector plane, in W/m2

It is seen from the graph that at point A, the performance of the FPC and ETC is the same. As ΔT increases from reference point A, ETC performs better than FPC, whereas with the decrease of ΔT from reference point A, FPC performs better than ETC.

Table 2

Temperature difference °C	0	10	15	20	25	30	35	40	45	50	55	60	70	80
Plate solar heater efficiency	0.74	0.68	0.66	0.63	0.60	0.57	0.55	0.52	0.49	0.46	0.43	0.41	0.35	0.30
ETC solar heater efficiency	0.59	0.56	0.55	0.54	0.53	0.51	0.50	0.49	0.48	0.46	0.45	0.44	0.41	0.39

The efficiency curve test

The efficiency curve is derived from Table 2 above. When the solar radiation is 800w/m² and the temperature difference is 50°, performance of both the collectors is the same. As the temperature difference decreases, FPC performance is better, and when the temperature difference increases, ETC performance is better. Going by the results of the study conducted by the Beijing Solar Energy Institute, it is clear that FPC will perform better in hot climatic conditions, whereas ETC will perform better in cold climatic conditions.

In a tropical country like India, where seasonal variations are quite wide, the solar water heater should be selected considering the winter climatic conditions. Table 3 below gives the temperature of some selected places across the country in the month of December.

Desired temperature of hot water: The required temperature of hot water will vary depending on the application, and accordingly, a suitable technology must be selected. The following table provides a general guideline for the selection of a suitable technology for various temperature applications.

Table 3

Application	Technology
Low temperature application from 40° C up to 80° C	FPC / ETC
Medium temperature application from 80° C to 120° C	Heat pipe ETC
High temperature application from 120° C to 250° C	Solar concentrator
Low temperature commercial application (e.g. swimming pool)	FPC / ETC

The following graph shows the performance of FPC and ETC with different solar radiation intensity for different applications. However, the customer's concern is the performance,

durability and reliability of the entire system and not merely the performance of the collector. Therefore, the customer must pay attention to the following points as well, while selecting the technology.

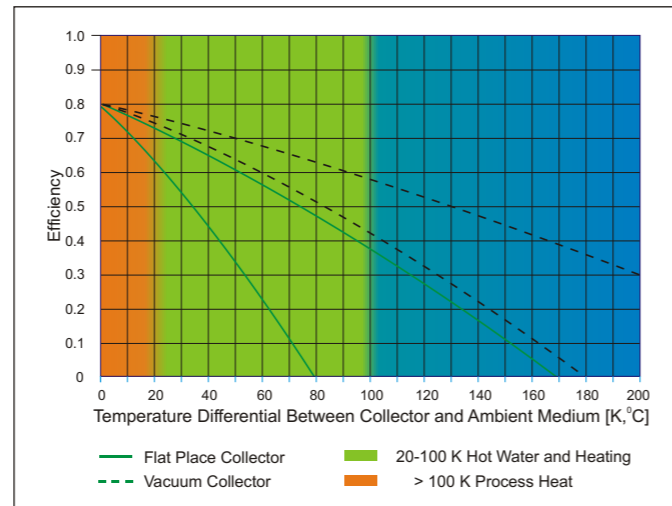

Graph 2

Water quality: Water quality plays an important role in the selection of the technology as well as the heat exchange mechanism. The selection of technology and material based on water quality is outlined below.

Temporary hard water

When temporary hard water is heated, the dissolved material in water separates. This material accumulates in the different parts of the collector system. This is called scale formation. The formation of scale is faster in an FPC-based system than in an ETC based system. However, the scale formation may take place in an ETC based system as well. In such kind of water, indirect heating through a heat exchanger is recommended. In case of indirect heating, scale formation takes place at the heat exchanger surface, which can be easily cleaned at periodic intervals.

However, newer technologies are coming in where the inner surface of the collector tubes is treated with a special chemical, to reduce scale formation. The customer may seek specific details of the technology along with the manufacturer's specific guarantee, before going in for direct heating of hard water (with temporary hardness).

Permanent hard water

Permanent hard water does not create problems in the performance of FPC or ETC based systems. However, if the system remains filled with water during summer and is overheated continuously, concentration of the dissolved solids goes up, causing a formation of scale, over a period of time.

Saline Water

Saline water corrodes mild steel, galvanized piping as well as stainless steel. Copper is not affected to a great extent. Therefore, in saline atmosphere, both FPC and ETC can be used. However, a stainless steel storage tank must be avoided. Instead, a mild steel storage tank can be used with proper treatment and paint protection. Regular maintenance is necessary in saline water conditions.

Acidic Water

Acidic water is corrosive to mild steel, galvanized iron, copper and other metals. It is also corrosive to stainless steel if the water contains sulfides, chlorides and fluorides. ETC-based systems should be used in such water conditions. However, such water quality is rare.

Alkaline Water

This is the most common water and moderate alkalinity is tolerated by mild steel, copper, stainless steel and galvanized iron. However galvanized iron starts losing zinc, which deposits on copper surfaces in the same system. Both FPC and ETC can be used in such water conditions. Insulated PVC pipes may be used instead of GI pipes, to avoid zinc depletion.

Water with high turbidity

Turbidity in water is because of a high amount of suspended solids. These solids will settle down slowly when the water stays for a long time in any container. These suspended solids are often charged particles. The charge gets neutralized slowly in contact with metals and slow settling takes place. Turbid water should be avoided in solar water heating systems, as it affects both FPC as well as ETC systems. If turbidity in water cannot be avoided, periodic maintenance must be carried out for the reliable and smooth operation of the system.

Treated water (for removing hardness)

Water treatment is usually done before feeding it into the boiler, in order to remove the hardness. by replacement of scale forming materials with sodium chloride. This water is also not suitable for stainless steel tanks.

Other environmental factors: In areas where hail is common, ETC should not be used as the glass tubes are likely to break due to hail-storms. Similarly in areas where animals like monkeys or cats frequent the solar water heater installation area, glass tubes of ETC may break, leading to a system shutdown. Therefore it is advisable not to use ETC-based systems in these areas.



Chapter 3

Sizing of the Solar Water Heater System

Introduction

It is extremely important to select the correct size of a solar water heater system. The solar water heater sizing needs to be done based on the hot water requirements and the hot water use habits of the members in a family. The basic idea of having a solar water heater is to reduce electricity consumption for water heating. An undersized system is insufficient to meet the hot water requirement, and an oversized system will result in overheating of the water. As a back-up system is required for cloudy days, it may be possible to manage with a marginal back-up use in extreme weather, to optimize the size of the system for use through the rest of the year.

Objective

The basic objective of this chapter is to provide a simple general guideline in selecting the right size of solar water heater. The selection of the solar water heater system in large residential, commercial and industrial applications is complex in nature and therefore, elaborate calculations may be necessary to size the solar water heater system. However the following guidelines can be used fairly accurately for small residential applications and to get a general idea about the size of the solar water heater systems for large residential and commercial installations.

Sizing of the solar water heater system

The requirement of hot water varies from person to person. However, it is estimated that the average hot water requirement per person per day in an average household in India is around 40 liters. The following two tables show the hot water requirement for different applications in Indian households and small commercial establishments respectively.

Table 4: Water consumption pattern for residential applications at 40 degree centigrade

Water consumption pattern in high-end bungalows in cities		Liters
Bathing per person per day		80
Wash basin per person per day		20
Kitchen wash per person per day		15
Clothes wash per person per day		10
Heat loss and hot water wastage factor		30%
Water consumption pattern in high-end residential flats in cities		
Bathing per person per day		60
Wash basin per person per day		10
Kitchen wash per person per day		15
Clothes wash per person per day		10
Heat loss and hot water wastage factor		25%
Water consumption pattern in average residential flats in cities		
Bathing per person per day		40
Wash basin per person per day		10
Kitchen wash per person per day		15
Clothes wash per person per day		00
Heat loss and hot water wastage factor		20%
Water consumption pattern in semi-urban households		
Bathing per person per day		40
Wash basin per person per day		10
Kitchen wash per person per day		00
Clothes wash per person per day		00
Heat loss and hot water wastage factor		20%
Water consumption pattern in rural households		
Bathing per person per day		40
Wash basin per person per day		00
Kitchen wash per person per day		00
Clothes wash per person per day		00
Heat loss and hot water wastage factor		15%

Table 5: Water consumption pattern in small commercial establishments, at 40 degrees centigrade

Water consumption in beauty saloons		Liters
Shaving per person		0.5
Hair rinsing per person		05
Water consumption in small clinics / dispensaries		
Hot water per patient		05
Water consumption in small hospitals (30 beds or less)		
Hot water per patient		60
Water consumption in restaurants / canteens		
Hot water per guest		05
Water consumption in small offices		
Hot water requirement per employee		02
Water consumption in hostels		
Hot water requirement per student		40
Water consumption in large hospitals (more than 30 beds)		
Hot water requirement per bed		300
Water consumption in large hotels		
Hot water requirement per room		300 - 600

Based on the above table, we can calculate the approximate size of solar water heating system required. The following illustration can help the user to calculate the approximate hot water requirement and corresponding size of the solar water system to ensure the required amount of hot water use only for residences and small commercial establishments, for bathing and hand washing applications.

The illustration is for an average residential flat in a city area, with 4 people staying in the flat. (Typical size of a nuclear family.)

Table 6:

Sl. No.	Description	Water/person/day	No. of persons	Total water requirement
01	Bathing	40	4	160
02	Wash basin	10	4	40
03	Kitchen wash	15	4	60
04	Clothes wash	0	4	0
05	Total requirement			260

Therefore the total hot water requirement at 40° C for a family of 4 in an average residential flat in a typical city, is 260 liters. There will also be heat loss in the pipes and mixing of cold water with the hot water in the hot water tank. Considering a heat loss factor of 20% for an average residential flat in the city area, the hot water requirement will be:

Table 7:

Sl. No.	Description	% loss of total requirement	Total water requirement
06	Heat loss and hot water wastage factor	20	52
07	Total hot water requirement at 40° C.		312

Hot water is required mainly in the winter season, and therefore, the system should be designed to meet the hot water requirement during winter. Table 7 gives the hot water output of a typical 100 liter system at 60° C, but the output varies from place to place depending upon environmental conditions.

a) For example, if a user lives in Leh, he will get 89 liters of hot water at 60° C from a 100 liter system, when the cold water temperature is 6° C. The ratio of cold water to hot water mix is given by the following formula:

$$\frac{\text{Quantity of cold water}}{\text{Quantity of hot water}} = \frac{\text{Hot water temperature} - \text{Used water temperature}}{\text{Mean water temperature} - \text{Cold water temperature}}$$

$$= \frac{\text{Quantity of cold water}}{\text{Quantity of hot water}} = \frac{60 - 40}{40 - 6} = \frac{20}{34} = \frac{1}{1.7}$$

From the above, we can conclude that 116 liters of cold water at 6° C needs to be mixed with 196 liters of hot water at 60° C to get 312 liters of water at 40° C. Now from Table 7, we can see that a 100 liter system at Leh can deliver 89 liters of hot water per day. Therefore, to get 196 liters of hot water, the collector area should be 4.2 sq meters [2 x 196/89 = 4.2]. Considering the annual climatic condition of Leh, 200 liters of storage tank capacity is more than sufficient. Therefore, the size of the solar water heating system should be as follows:

Hot water requirement per day at 40° C	312 liters
Size of the storage tank	200 liters
Size of the collector area	4 sq meters

b) If we need to calculate the size of a solar water heating system for Delhi, we get:

$$\frac{\text{Quantity of cold water}}{\text{Quantity of hot water}} = \frac{\text{Hot water temperature} - \text{Used water temperature}}{\text{Used water temperature} - \text{Cold water temperature}}$$

$$= \frac{\text{Quantity of cold water}}{\text{Quantity of hot water}} = \frac{60 - 40}{40 - 10} = \frac{20}{30} = \frac{2}{3}$$

Therefore, 125 liters of cold water at 10° C needs to be mixed with 187 liters of hot water at 60° C to get 312 liters of water at 40° C. Now from Table 7, we can see that a 100 liter system in Delhi can deliver 102 liters of hot water per day. Therefore, to get 187 liters of hot water, the collector area should be 3 sq meters [2 x 187/102 = 3.6]. However, if 3.6 sq meters is not a standard size of collector available in the market, the customer should go for the next higher size. Hence the size of the solar water heating system should be as follows:

Hot water requirement per day at 40° C	312 liters
Size of the storage tank	200 liters
Size of the collector area	4 sq meters

c) If we need to calculate the size of a solar water heating system for Kolkata, we get:

$$\frac{\text{Quantity of cold water}}{\text{Quantity of hot water}} = \frac{\text{Hot water temperature} - \text{Used water temperature}}{\text{Used water temperature} - \text{Cold water temperature}}$$

$$= \frac{\text{Quantity of cold water}}{\text{Quantity of hot water}} = \frac{60 - 40}{40 - 19} = \frac{20}{21} = \frac{1}{1}$$

Therefore, 156 liters of cold water at 19° C needs to be mixed with 156 liters of hot water at 60° C to get 312 liters of water at 40° C. From Table 7, we can see that a 100 liter system in Kolkata can deliver 127 liters of hot water per day. Therefore, to get 156 liters of hot water, the collector area should be only 2 sq meters [2 x 156/127] = 2.4].

However, to store hot water close to 156 liters, 200 liters of storage tank capacity should be used. But if hot water is used regularly, a 150 liter storage tank is also more than sufficient. It is always advisable to have a storage tank of a little higher capacity, to avoid overheating during summer season. Therefore, the size of the solar water heating system should be as follows:

Hot water requirement per day at 40° C	312 liters
Size of the storage tank	150-200 liters
Size of the collector area	2 to 3 sq meters

d) If we need to calculate the size of a solar water heating system for Mumbai, we get:

$$\frac{\text{Quantity of cold water}}{\text{Quantity of hot water}} = \frac{\text{Hot water temperature} - \text{Used water temperature}}{\text{Used water temperature} - \text{Cold water temperature}}$$

$$= \frac{\text{Quantity of cold water}}{\text{Quantity of hot water}} = \frac{60 - 40}{40 - 23} = \frac{20}{17}$$

Therefore, 163 liters of cold water at 23° C needs to be mixed with 149 liters of hot water at 60° C to get 312 liters of water at 40° C. From Table 7, we can see that a 100 liter system in Mumbai can deliver 171 liters of hot water per day. Therefore, to get 149 liters of hot water, the collector area should be only 1.7 sq meters [2 x 149/171 = 1.8]. If the minimum size of collector available in the market is 2 sq meters, the customer will have to select 2 sq meters as the required size.

However, to store hot water close to 171 liters, 400 liters of storage tank capacity should be used. But if hot water is used regularly, a 300 liter storage tank is more than sufficient. It is always advisable to have a storage tank of a little higher capacity to avoid overheating during summer season. Therefore, the size of the solar water heating system should be as follows:

Hot water requirement per day at 40° C	312 liters
Size of the storage tank	300 - 400 liters
Size of the collector area	1.8 - 2 sq meters

e) If we need to calculate the size of a solar water heating system for Bangalore, we get:

$$\frac{\text{Quantity of cold water}}{\text{Quantity of hot water}} = \frac{\text{Hot water temperature} - \text{Used water temperature}}{\text{Used water temperature} - \text{Cold water temperature}}$$

$$= \frac{\text{Quantity of cold water}}{\text{Quantity of hot water}} = \frac{60 - 40}{40 - 16} = \frac{20}{24} = \frac{5}{6}$$

Therefore, 142 liters of cold water at 16°C needs to be mixed with 170 liters of hot water at 60°C to get 312 liters of water at 40°C. From Table 7, we can see that a 100 liter system in Bangalore can deliver 118 liters of hot water per day. Therefore, to get 170 liters of hot water, the collector area should be only 3 sq meters [2 x 170/118 = 2.85]. If 3 sq meters is not the standard size available in the market, the customer can go for the next higher size.

However, to store hot water close to 142 liters, 300 liters of storage tank capacity should be used. But, if hot water is used regularly, a 200 liter storage tank is more than sufficient. It is always advisable to have a storage tank of a little higher capacity to avoid overheating during summer season. Therefore, the size of the solar water heating system should be as follows:

Hot water requirement per day at 40°C	312 liters
Size of the storage tank	200 - 300 liters
Size of the collector area	3 - 4 sq meters

f) If we need to calculate the size of a solar water heating system for Chennai, we get:

$$\frac{\text{Quantity of cold water}}{\text{Quantity of hot water}} = \frac{\text{Hot water temperature} - \text{Used water temperature}}{\text{Used water temperature} - \text{Cold water temperature}}$$

$$= \frac{\text{Quantity of cold water}}{\text{Quantity of hot water}} = \frac{60 - 40}{40 - 22} = \frac{20}{18} = \frac{10}{9}$$

Therefore, 163 liters of cold water at 22°C needs to be mixed with 149 liters of hot water at 60°C to get 312 liters of water at 40°C. From Table 7, we can see that a 100 liter system in Chennai can deliver 136 liters of hot water per day. Therefore, to get 149 liters of hot water, the collector area should be only 2.2 sq meters [2 x 149/136 = 2.2].

However, to store hot water close to 149 liters, 250 liters of storage tank capacity should be used. But if hot water is used regularly, a 150 liter storage tank is more than sufficient. It is always advisable to have a storage tank of a little higher capacity to avoid overheating during summer season. Therefore, size of the solar water heating system should be as follows:

Therefore, the size of the solar water heating system should be as follows:

Hot water requirement per day at 40°C	312 liters
Size of the storage tank	150 - 250 liters
Size of the collector area	2 sq meters

Notes:

- 1) Based on the technology, the output of the solar water heater may vary by ± 10%.
- 2) The above is a general guideline to illustrate how the sizing of a solar water heating system should be done. Customers living in different places may calculate their hot water requirements and corresponding size of solar water heating system in a similar way. If the place does not appear in Table 8 below, the customer can consider the nearest place from his place of living, from Table 7.
- 3) For calculations of hot water requirements and sizing of solar water heating systems, the customer may refer to the solar water heater calculator in the following URL: www.copperindia.org OR www.mnre.gov.in

Table 8:

Collector inclination and winter output at 60 degrees at different places for a 2 sq meter collector. On an average clear day in December in the plains and in the month of April in the hilly areas, a variation of + - 10% is likely with collectors from different sources.

Place	Latitude Incline Degree	Collector Temperature Degree	Day Ambient Temperature Degrees C	Cold Water Radiation Degrees C	Solar Incline KWh/day	At Temperature KWh/day	Hot Water Output Degrees C	Approx Litres/day
North Hills								
Leh	34.15	34	10	6	6.706	6.28	60	89
Srinagar	34.08	34	15	10	6.281	6.28	60	105
Ranikhet	29.75	30	18	15	5.388	5.37	60	101
North Plains								
Amritsar	31.83	47	16	10	3.488	6.04	60	93
Chandigarh	30.73	46	16	12	3.464	5.79	60	94
Dehradun	30.32	45	12	8	3.531	6.06	60	86
Pant Nagar	29	44	12	8	3.801	5.91	60	84
New Delhi	28.58	43	14	10	3.95	6.64	60	102
Agra	27.17	42	16	11	4.104	6.81	60	109
Allahabad	25.45	40	20	15	4.347	6.99	60	127
Lucknow	26.73	41	20	15	4.198	6.87	60	125
Varanasi	25.45	40	20	15	4.376	6.97	60	127
East Plains								
Patna	25.5	40	20	15	4.324	6.73	60	123
Kolkata	22.65	38	23	19	4.168	6.09	60	127
Ranchi	23.42	38	19	12	4.891	7.71	60	130
Bhubaneswar	20.25	35	25	21	5.128	7.55	60	168
Cuttack	20.48	35	23	19	4.956	7.25	60	150
Northeast Hills								
Imphal	24.77	40	17	10	4.363	6.82	60	107
Shillong	25.57	25	18	15	5.688	5.60	60	105

Place	Latitude Inclination Degree	Collector Temperature Degree	Day Ambient Temperature Degrees C	Cold Water Radiation Degrees C	Solar Inclination KWh/day	At Temperature KWh/day	Hot Water Output Degrees C	Approx Litres/day
Northeast Plains								
Siliguri	24.83	40	20	14	4.176	6.26	60	111
Dibrugarh	27.48	42	20	14	3.74	5.71	60	101
Gauhati	26.1	41	22	18	4.018	6.29	60	126
Agartala	23.88	39	23	18	4.094	5.92	60	120
West Plains								
Bikaner	28	43	19	13	4.208	7.21	60	124
Jaisalmer	26.9	42	18	12	4.361	7.41	60	124
Jaipur	26.82	42	18	12	4.461	7.58	60	127
Jodhpur	26.3	41	21	14	4.508	7.57	60	136
Kota	25.18	40	20	13	4.67	7.72	60	134
Udaipur	24.38	39	21	14	4.71	7.54	60	135
Ahmedabad	23.07	38	24	17	4.822	7.64	60	151
Baroda	22.3	37	27	20	4.886	8.03	60	176
Surat	21.2	36	27	22	4.859	7.13	60	166
Rajkot	23.42	38	26	22	4.764	7.22	60	167
Nagpur	21.15	36	23	16	4.814	7.22	60	138
Mumbai	19.12	34	27	23	4.948	7.13	60	171
Pune	18.53	33	22	15	5.03	7.11	60	132
Solapur	17.67	32	25	18	5.159	7.16	60	147
Goa	15.48	30	26	21	5.37	7.22	60	162
Central Plains								
Gwalior	26.23	41	20	13	4.303	7.11	60	123
Bhopal	23.27	38	24	17	4.652	7.28	60	144
Indore	22.72	38	23	16	4.772	7.28	60	139
Jabalpur	23.15	38	22	15	4.516	7.00	60	130
Satna	24.37	39	20	13	4.54	7.36	60	128
Raipur	21.27	36	20	13	4.54	7.36	60	128
South Hills								
Kodaikanal	10.23	25	15	9	5.19	6.22	60	93
Ootacamund	11.4	26	12	6	5.264	6.46	60	88
South Plains								
Hyderabad	17.45	22	24	17	5.133	7.03	60	139
Bangalore	12.95	28	22	16	4.949	6.20	60	118
Coimbatore	11	26	26	20	5.141	6.30	60	138
Chennai	13	28	26	22	4.707	5.83	60	136
Kanyakumari	8.08	23	26	22	5.082	6.01	60	140
Thiruchirapalli	10.77	26	26	21	4.949	6.08	60	138
Trivandrum	8.48	23	26	22	5.498	6.58	60	153
Vishakhapatnam	17.72	32	24	20	4.992	6.92	60	149
Mangalore	12.92	28	28	22	5.302	6.79	60	160
Port Blair	11.67	26	28	24	4.641	5.63	60	143





Chapter 4

Cost Evaluation of Solar Water Heating Systems

Introduction

There is a general tendency of customers to look at the initial cost while taking purchase decisions. However, products which are initially cheaper may cost more over the long term, when compared with other similar products. Therefore, the concept of the life cycle cost evaluation of a solar water heater is important for the customers while taking purchase decisions.

Objective

The objective of this chapter is to introduce the principles of life cycle cost evaluation while taking purchase decisions of a solar water heater. The initial cost of a solar water heater system is recovered through savings of energy bills over a period of time.

Life cycle cost principles

There are many factors to be considered while evaluating the life cycle cost of a solar water heating system. These factors are: interest rate, inflation rate, unit cost of electricity, operation & maintenance cost and solar water heater service life. All these factors are affected by fluctuations in the economy, government policies, electricity tariffs, etc.

Interest rate: Interest rate is an important part of the loan. The terms and conditions of a loan, such as the interest subsidy offered by MNRE, loan terms, pre-payment penalty, time taken for approval etc. need to be checked by the customers before finalizing loans with a particular bank.

Inflation rate: This factor shows the effect of inflation rate on the real value of money. A substantial increase in the price of a solar water heater system is due to the increase in the inflation rate, which means a decrease in the value of money. With the rise in inflation rate, the price of the goods will increase.

Electricity/ Fuel rate: One of the main reasons to go in for a solar water heating system is to cut down on electricity consumption. The unit cost of electricity varies from place to place and the electricity tariff in a state which is revised from time to time, is determined by the state electricity regulatory commission. It is very important to understand how much savings are generated by a reduction in electricity consumption from the solar water heating system over its service life.

Operation & maintenance cost: The operation and maintenance cost should be calculated from the accumulated expenses under the following heads:

- Solar water heater system cost (collector, storage tank with necessary plumbing interconnection and installation)
- Freight & insurance cost
- Loading & unloading cost at the site of installation
- Excise, customs, octroi and sales tax levied on the products
- Administrative and general costs
- Regular and periodic maintenance cost
- Depreciation cost

This cost needs to be calculated based on information from many manufacturers, different categories of users and solar water heater experts. The more realistic the expenses, the more accurate the O&M cost. It is recommended that the customer must ask the manufacturer the O&M cost per liter of hot water per year to arrive at the O&M cost of the entire system for a year.

Solar water heater service life: The service life of a solar water heater system varies widely depending upon the technology, manufacturing quality, water quality and maintenance of the system. Flat plate collectors may be in service even after 20 years of operation, whereas glass based evacuated tube collectors may go out of service even before 5 years of service. After discussions with reputable solar water heater manufacturers, it is safe to say that the recommended service life of a flat plate tube collector is 15 years, while that of glass evacuated tube collectors is 5 years.

Table 9:

Financial Analysis of the Solar Heating System at Chelsea Mills, Manesar

Solar Flat Plate Collector	410 nos.
Size of Tank	10000 ltrs.
Size of System	50000 ltrs.
Energy Saved	271 liters of diesel per day
Cost of Project	46.50 lacs
Year of Installation	2006
Depreciation Benefit	80% for 1st year
Diesel Savings (325 days of operation)	271.00 liters / day
Annual Diesel Savings	88075 liters / year
Annual Energy Saving	Rs. 1585350 @ Rs. 18/liter diesel in 2006; Rs. 1761500 @ Rs. 20/liter diesel in 2007; Rs. 2201875 @ Rs. 25/liter diesel in 2008; Rs. 2201875 @ Rs. 25/liter diesel in 2009.
Pay Back Period	2.37 years

Table 10:

Net return on investment / year	Rs. 30,48,619				
Net % return on investment / year	66%				
Detail cash flow analysis					
Project cost	Rs. 46,50,000				
Interest on capital employed	12%				
Operation & maintenance cost	2% of project cost, escalating at 10% per year				
Fuel cost	Rs. 25/liter 10% escalation per annum after 2009				
Quarterly cash flows					
Year	2006	2007	2008	2009	2010
Savings	1585350	1761500	2201875	2201875	2422063
Interest payment	558000	76985	90487	0	0
Maintenance	93000	102300	112530	123783	136161
Depreciation benefit	1149480	229896	45979	0	0
Net cash flow	2083830	1812111	2044837	2078092	2285901
Cumulative net inflow	2083830	3895941	5940778	8018870	10304771
Year	2011	2012	2013	2014	2015
Savings	2664269	2930696	3223765	3546142	3900756
Interest payment	0	0	0	0	0
Maintenance	149777	164755	181231	199354	219289
Depreciation benefit	0	0	0	0	0
Net cash flow	2514491	2765940	3042534	3346788	3681467
Cumulative net inflow	12819263	15585203	18627737	21974525	25655992
Year	2016	2017	2018	2019	2020
Savings	4290831	4719915	5191906	5711097	6282206
Interest payment	0	0	0	0	0
Maintenance	241218	265340	291874	321061	353167
Depreciation benefit	0	0	0	0	0
Net cash flow	4049613	4454575	4900032	5390035	5929039
Cumulative net inflow	29705606	34160180	39060213	44450248	50379287



Chapter 5

Installation of the Solar Water Heater System

Introduction

The performance of solar water heater will depend largely on the proper installation of the system. Following the proper installation method is important both for the safety of the installers during installation as well as the safety of the people post-installation.

Objective

The objective of this chapter is to give a general idea of solar water heater classifications based on installation practices, and to lay the basic guidelines during the installation of the solar water heater system. Depending upon the kind of system, fluid circulation principles, structure of the installation plane etc., the installation practices differ.

Solar water heater classification based on installation practices

Prefabricated solar systems: Prefabricated systems are sold as a single product under a single brand name. These kinds of systems are sold as a package and are ready for installation at sites. These are normally direct systems. If any of the components of the prefabricated systems is altered, the system no longer remains a prefabricated system. In India, we do not have any standard for prefabricated systems, but efforts are on to develop one in line with EN- 12976 1: 2000 and EN - 12976 2: 2000.

Custom-built solar systems: Custom-built systems are normally built with a set of components to meet the specific demand of the customer. Here each individual component is tested separately as per the standard and then the test results are combined together to review the complete system. India has a BIS standard for the collector under IS12933:2003. However, BIS does not have a standard for the other components of the system. Efforts are on to develop standards for each component of the custom built system in line with ENV 129771:2000.

Thermo siphon system: This is the most widely used system configuration. In the thermo siphon system, cold water will flow into the system due to the pressure difference, and therefore, the source of the cold water must be placed at least 7 feet or more higher above the terrace level where the solar water heater system will be installed.

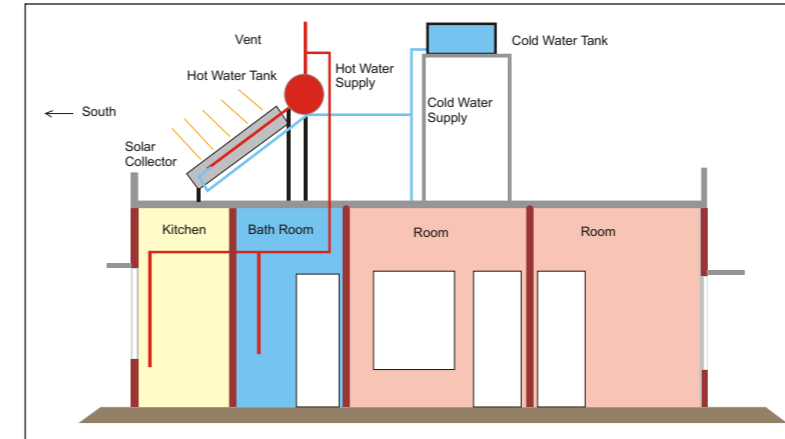

Fig 2: Thermo siphon system with overhead tank

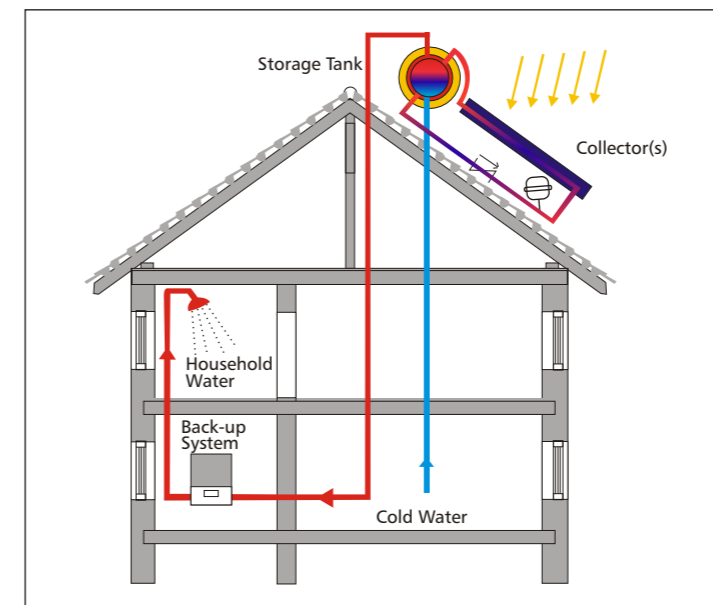

Fig 3: Thermo siphon system with pressurized water supply

Forced circulation system: In forced circulation, the source of the cold water supply can be at any level, as water will be pumped into the system. It is recommended to use the forced circulation system where the source of cold water is not placed at a sufficient height. In case of large systems also, it is recommended to have the forced circulation system to attain sufficient water pressure and to maintain uniform water temperature.

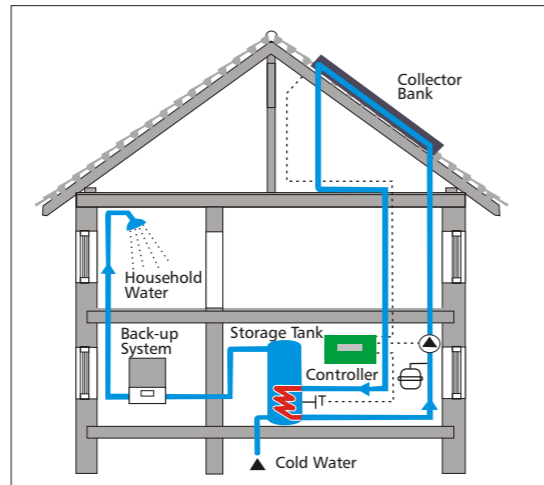

Fig 4: Forced circulation with heat exchanger

Solar water heater with heat exchanger: Water quality and ambient temperature varies from place to place. If the water is hard, it will deposit minerals inside the water tubes of the solar collector. As a result, the collector tubes may get blocked and performance of the system gets reduced drastically.

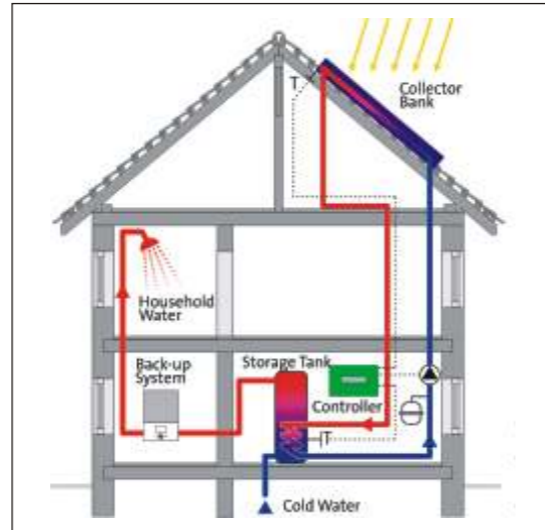

Fig 5: Forced circulation with heat exchanger

Compact type (direct insertion type in case of ETC): Most solar water heaters installed in the country are the compact type. Here either the solar collectors are directly inserted into the hot water storage tank (ETC-based system) or the collector and the storage tank are placed together with a small, flexible interconnection pipe. (FPC-based system).



Fig 6: Compact type FPC-based system



Fig 7: Compact type ETC-based system

Body-separation type system: Body-separation type solar water heaters are of the forced circulation type system and normally come with a heat exchanger. Here, the solar collectors are separated from the water tanks and the collectors may be installed either on the roof or on the façade, as per convenience of installation and operation.

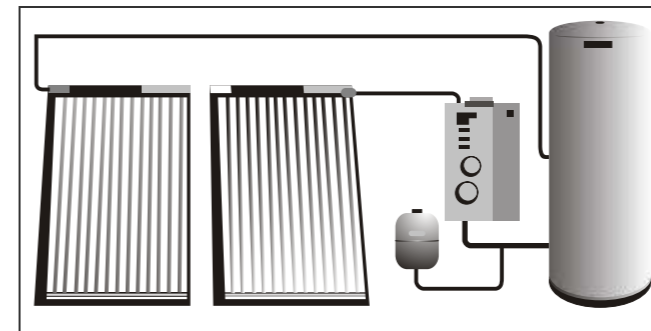

Fig 8: Body separation type system

Planning of installation

The installation of a solar thermal heating has a series of processes.

Design:

Design means selection of the right technology, proper sizing of the solar water heating system and selection of the locations for the collectors and storage tank installation in the building. The design drawing must be prepared before installation. (Refer to Chapter 2 and Chapter 3).

Recommended clearance between collector banks:

In an assembly of collector banks, installation should be done in such a way that the shadow of one collector bank does not fall on the other, to get maximum output.

Assembly of collectors:

An assembly of collectors should be installed in such a way that it is easy for regular and periodic maintenance.



Fig 9: Assembly of collectors, easy to maintain

Support structure:

The support structure should be stable and resistant to corrosion and the angle of tilt must be proper. The support structure must be anchored to the roof or ground firmly by cement concrete blocks or anchor bolts. The anchoring must be such that even strong winds are not able to topple the structure and solar collectors.

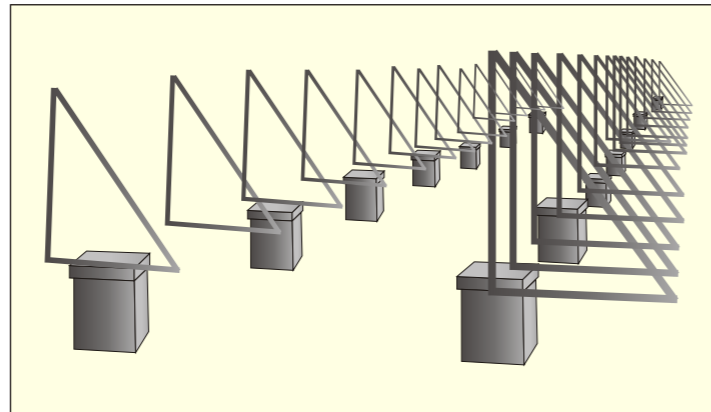

Fig 10: Fabrication of support structure

Storage tank:

Proper attention should be paid while installing a hot water storage tank on the rooftop. (The columns and beams of the building's terrace or roof should be able to take the load of the tank with water.) Attention to small things such as whether the storage tank can pass through the terrace door or whether there is sufficient place for a crane to operate for lifting the storage tank up to the terrace, are important. The following points should be taken care of while installing the storage tank:

- Proper insulation of the storage tank
- Proper installation of the sacrificial anode
- Avoid usage of different materials to prevent galvanic corrosion



Fig 11: Installation of storage tank

The connection of the hot water storage tanks is also important to receive the maximum output. The figure below shows the right and wrong methods of interconnections of the storage tanks.

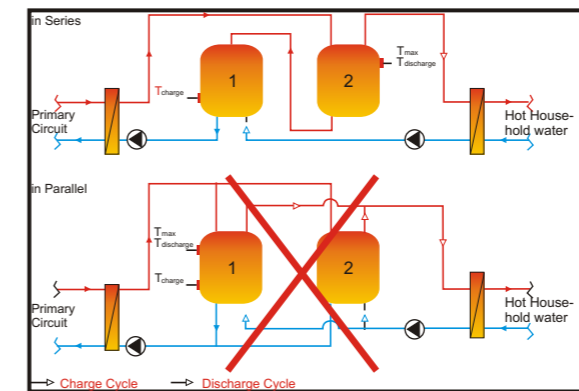

Fig 12: Interconnection of storage tanks

Plumbing:

The compact type ETC system does not require any piping between the collector and the hot water storage tank, whereas the FPC-based direct system requires a flexible connection between the collector and the storage tank.

The body separation type system (both ETC and FPC) require internal piping between the collector and the hot water storage tank. Since the body separation type system normally comes with a heat exchanger, the piping needs to be insulated adequately to limit heat loss.

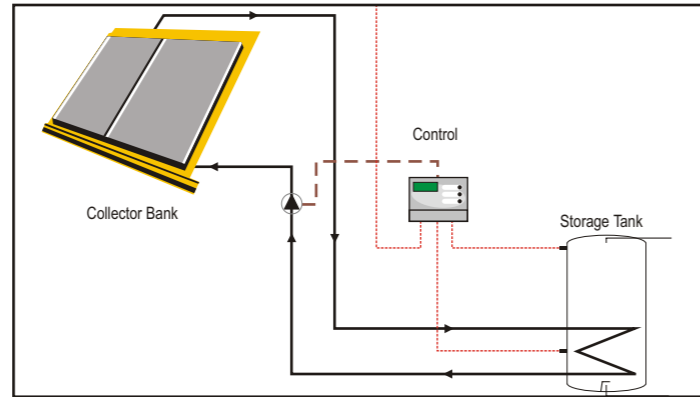

Fig 13: Body separation type collector

Cold water plumbing:

1. A PVC or GI pipe may be used up to the cold water inlet of the system. Proper care should be taken so that there is no leakage at the joints. If a GI pipe is used, it should be painted externally to avoid galvanic corrosion.
2. The connection of cold water supply to the collectors should be either horizontal or slanting downwards to the collector.
3. For the thermo-siphon system, the height of the bottom of the cold water source (typically a storage tank) should be at least 7 feet or more above the terrace level where the solar water heating system is installed.
4. Separate piping should be done from the cold water source (storage tank) to the hot water storage tank.
5. In the cold water line, a separate gate valve and a union have to be provided at a point near and below the solar hot water storage tank.
6. A cold water air vent pipe is to be provided at the point from where the cold water pipe from the cold water source drops down.
7. The top height of the air vent pipe provided at the drop down point should be at least 2 feet higher than the cold water source overflow outlet.
8. If a separate cold water tank is provided for the solar water heater, the capacity of the cold water tank should be at least double the size of the solar water heating system.
9. The cold water tank should be kept clean and covered.
10. It is recommended to use a non-return valve at the inlet of the cold water into the hot water storage tank.

Hot water plumbing:

1. The hot water connection can be done with insulated GI or copper pipes. Special attention should be given to ensure that the plumbing does not get damaged due to thermal expansion and contraction.

2. Zigzag piping is likely to create air bubbles inside the pipes, blocking the flow of water, resulting in the system overheating and steam generation.
3. The hot water pipe should be of comparatively smaller diameter and of shorter length. Smaller diameter and shorter lengths will reduce heat loss.
4. The hot water air vent pipe should be at least 2 feet higher than the cold water air vent.
5. In the hot water delivery line, only one union has to be provided in the nearest point of the solar heating system.
6. If the hot water line is taken via a geyser, it should be connected to the outlet point of the geyser.

Table 11

The table below shows the pipeline capacity and the cold water expected to be removed in the morning from one meter of hot water pipe before the flow hot water starts.

Nominal pipe dia. GI medium class	Capacity/meter Liter/meter	Weight /meter (Kg)	Specific heat	Equivalent water from 20 to 60 deg. heating of pipe	Total hot water loss every morning per meter of pipe
15	0.201	1.22	0.11	0.134	0.34
20	0.367	1.58	0.11	0.174	0.54
25	0.581	2.46	0.11	0.271	0.85
32	1.012	3.15	0.11	0.347	1.36
40	1.371	3.61	0.11	0.397	1.77
50	2.206	5.1	0.11	0.561	2.77

Insulation:

All hot water piping needs to be insulated. The insulation is done with flexible foam materials like nitro-flex tubing or glass-wool pads or polyurethane pipe sections. The insulation is to be protected from rain water and solar radiation damage by covering it with aluminum, GI sheet or fibre-glass cladding.



Fig14: Insulation of hot water piping

Special attention must be paid to insulation if the hot water piping is inside a brick wall. The loss of heat to the wall from the pipe is many times more than the loss of heat from exposed pipe to air. Also cold water piping and hot water piping must be kept separate.

Orientation and angle of tilt:

The orientation of the collector and the angle of tilt are very important for optimum output of the solar system. Our country is located in the northern hemisphere of the earth. The sun in winter, rises in the south-east and sets in the south-west. The collectors for all locations in India should be oriented in a direction facing the south. At times, a compromise becomes essential due to the non-availability of an area where the solar collector can be oriented and located in a shadow-free area. The compromise must be limited to an angle of 15 degrees towards the west or east, for minimal effect on the output from the solar heating system.

The alignment of the axis of the earth in relation to the sun is such that the solar radiation reaches us from the southern sky tilted at an angle from the overhead position. The angle of tilt at noon corresponds to the latitude of the place on 22nd September. It becomes Latitude +23.5 degrees on 22nd December. The angle of tilt starts to shift in the other direction and it corresponds to the latitude of the place again on 22nd March. The shift continues till the angle of tilt reaches the latitude of the place - 23.5 degrees on 22nd June, around noon.

Graph 4

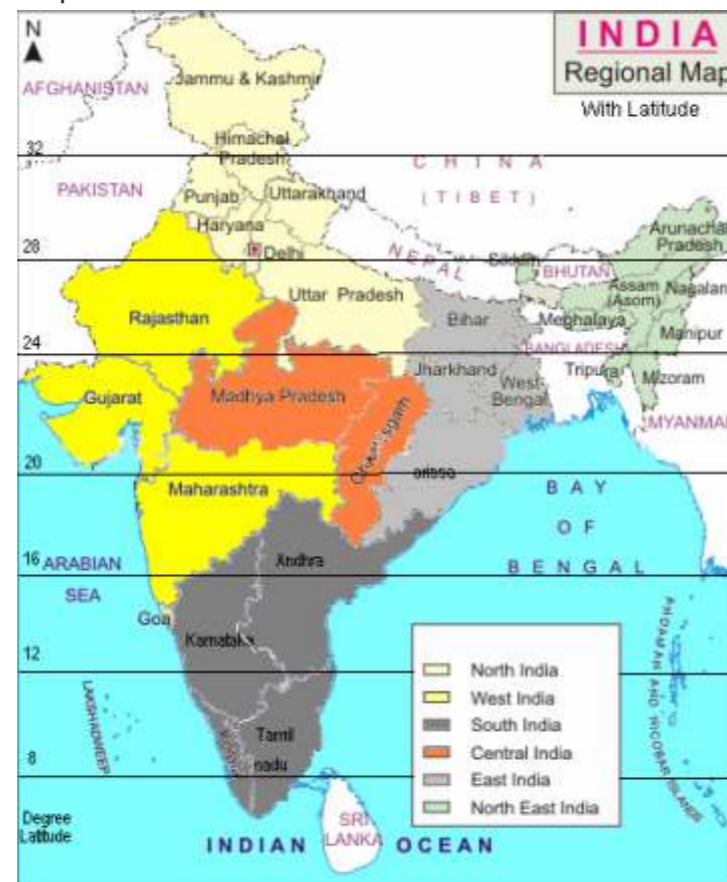

Since we require more hot water in winter than in summer, the orientation of the solar collector must be made to maximize noon time radiation on the collector in winter. Therefore the collector must be oriented facing south at an angle of +(10 to 15)degrees latitude from the horizontal.

If we require hot water equally in the winter and summer months, the collector's angle of tilt may be equal to the latitude of the place. If the requirement is higher in the summer months, the angle of tilt should be less than the latitude angle of the place. The latitude angle for the places is determined by the distance of these places from the equator. It increases as the distance from the equator increases. (e.g. The latitude of Bengluru is 13 degrees, Delhi is 29, and Srinagar is 34 degrees).

In some systems a number of solar collectors is required. It may not be possible to locate these in one line due to site restraints. In such cases it is necessary to keep an adequate distance between the collectors to ensure that the shadow of one collector does not fall on the front surface of the next collector.

The hot water storage tank is normally located behind the collector and higher than the collector. When more than one system is installed in a place, the shadow of one system should not fall on the collectors of the other system.

Specification:

Specification means listing down the key parameters of the solar water heater based on design consideration, environmental conditions, water quality and return on investment. (Refer to Chapter 1 and Chapter 4)

System dimensioning:

Once a particular manufacturer is shortlisted, the next step would be to determine the dimensions of the system based on the supplier's data. Here, the dimensions of the collector area, water storage tank etc. will be required to be plotted on the installation drawing.

Assembly & installation:

To install the system at the site, it is important to work on the required support structure. This will include fastening of the collector and storage tank, commissioning of the pipe work, pump system, control system and electrical back-up.

Once the assembly and installation is done, the solar water heater system should be tested and commissioned.

General considerations during installation planning

Shade: The collector must be installed in a shadow-free area. It should not be placed near a tree plantation. The trees may grow over a period of time and their shadow may fall on the collector. In an urban environment, it may not be possible to achieve total freedom from shadows throughout the day. In such cases, the system should be located in the most shadow-free area of the building's terrace. The aim should be to get a shadow-free area at least for 3 to 4 hours before and after noon. This is a compromise, and as a result, there will be a corresponding reduction in the output.

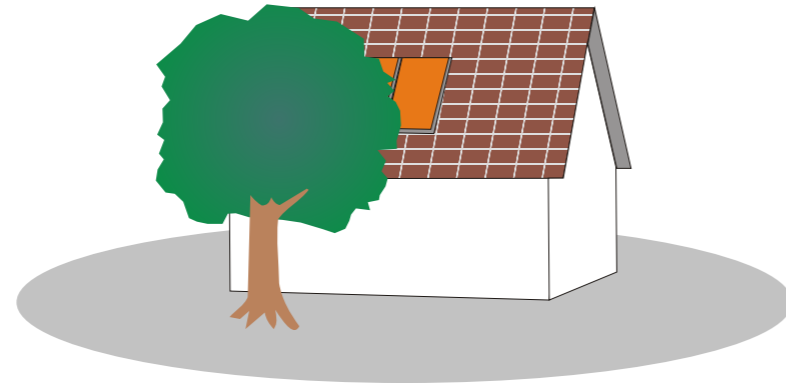

Fig15: Shadow of a tree on the collector

In the ETC-based system, the initial filling of water in the tank and tubes should be done in the morning when the tubes are cold. With sun exposure, the tubes may become quite hot and if filled at that time, it may result in the breakage of the tubes due to sudden cooling.

Statutory rules: It is important to keep in mind the national, state and local municipal standards while installing a solar water heating system.

Safety: Safety is the most important consideration while installing the system. Below are a few safety tips to be followed during the installation of a solar water heater.

- Wear proper safety clothes and tie yourself with safety rope during assembly.
- While working on roofs, be specially careful of loose tiles and electrical cables.
- Avoid working on inclined wet roofs during rainy days.

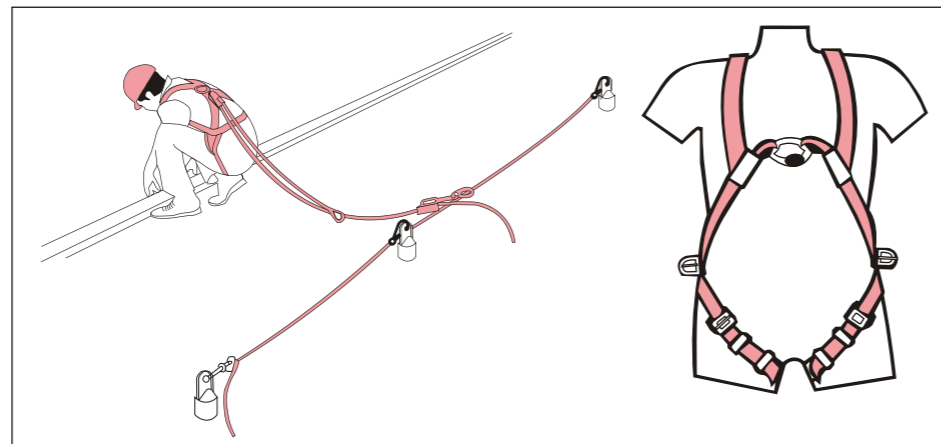

Fig16: Safety rules





Chapter 6

Maintenance and Trouble-shooting

Introduction

Regular and periodic maintenance is important for the durable service life of any equipment. Solar water heater systems too need regular periodic maintenance for satisfactory service.

Objective

The objective of this chapter is to explain the typical maintenance requirements of solar water heating systems. The chapter also covers the common problems customer may face, along with trouble-shooting mechanisms.

Regular and periodic checks and maintenance

1. The top glass cover should to be cleaned periodically to allow the maximum solar radiation to reach the absorber surface.
2. If the system is not being used at all in summer, the water from the system should be drained off completely in case of FPC systems, to avoid the boiling of water in the storage tank.
3. Look for any sign of leakages in the system, like the collector and plumbing joints, and have these rectified immediately. Leaving leakages unattended in insulated piping results in the corrosion of the pipes.
4. Check the back-up elements/thermostats every year before winter, and have these replaced if they have deteriorated.
5. For systems with heat exchangers installed with hard water, check for the water flow in the hot water pipes after each summer. At times, scale deposits choke the hot water outlet. In such cases, the hot water outlet, along with the heat exchanger, needs to be cleaned.
6. Check the physical condition of the supports. These may need to be painted periodically to avoid corrosion.
7. If the water quality is bad and unsuitable for the tank material, the tank may start leaking. Check for any leakages and recommend changes/replacements.
8. If there is any construction in the neighbourhood which is casting a shadow on the solar panel, the system may need to be shifted to a shadow-free location.
9. If there is any damage to the insulation cladding, it may need replacement or repair.

Trouble-shooting

1. If the pump is not operating during sunshine hours, this could be because of:
 - a. No electricity
 - b. Sensor malfunction
 - c. Controller malfunction
 - d. Pump failure
2. If the pump is operating with frequent ON / OFF, this could be because of a small gap between the ON and OFF temperature settings OR the pump circulation circuit is too large.
3. If the tank pressure is too high, it could be due to the high filling pressure OR because the vent / pressure release is not provided or not functioning properly.
4. If the tank pressure is too low, it could be because of leakage or loss of cold water supply.
5. If the pump does not stop in the evening, this could be because of a defective setting or defective sensors.
6. If the storage tank cools down too fast at night, it could be because the recirculation pump is not stopping at night or the insulation of the tank is damaged.
7. If the water does not heat sufficiently on clear days, it could be because of dust on the collectors, an undersized system or damage to the coating of the collector.



Chapter 7

Frequently Asked Questions (FAQs)

Does a solar water heating system work on cloudy days?

Solar water heating is done by the energy received from the sun. If the energy input is reduced or cut off by clouds, the heating of the water is reduced. All solar water heating systems have back-up heating devices for meeting these contingencies. In most solar water heating systems, the hot water heated on the previous day, is used in the morning of the next day. It will be known by evening if heating during the day has not taken place, and auxiliary heating can be switched on for heating in the night.

What is the life of the solar water heating system?

Solar water heaters are generally expected to last for 15 years, but some solar water heating systems installed in 1983-84 are still functional in most places. If the water quality is not a problem, one can expect a solar water heating system to last even for 30-40 years. Some preventive maintenance for the protection of exposed surfaces and pumps, valves, back-up systems and plumbing etc. may be required, as for other systems in a building.

Does the output from a solar water heating system decrease with age?

The output from a solar water heating system may marginally decrease over a period of time, but the decrease is normally not too much.

What are the regular maintenance requirements?

The surface of the collector must be periodically cleaned to remove dust from the top surface and get optimum output from the system. Occasional observation of the solar water heating system to eliminate any plumbing leakages may help. The exposed metal surfaces may be examined for any damage to paint etc. after the monsoon, to avoid further damage. Some rubber or plastic components may not last beyond 10 years and may require replacement. Auxiliary heating elements also do not last through the life of the solar water heating system, and require replacement at times.

What are the guarantees on solar water heating systems?

All solar water heating systems are guaranteed by the manufacturers for one year. Some manufacturers provide a guarantee of even 5 years. A large number of installers take annual maintenance contracts for larger systems for a fee, on mutually agreed terms.

Is it necessary to have a south-facing, shadow-free area for the installation of a solar system?

Solar water heating systems perform best in winter when installed facing south at an optimum angle. A variation of 15 degrees to the east or west does not affect the output significantly.



Annexure A

Introduction to Solar Water Heating

Heat transfer principles

The process by which solar energy reaches us in spite of such a large distance between the sun and the earth is called 'radiation'. This phenomenon of exchange or transfer of energy happens between any two objects facing each other, even when they are at a distance from each other, even when there is no other material (solid, liquid or gas) between the two objects.

When a solid object has a high temperature on one side and low temperature on the other side of it, an exchange of heat takes place from the high temperature side to the low temperature side. Consider the case of a spoon placed in a cooking pot. The portion of the spoon which is inside the pot, is at a higher temperature, as compared to the handle portion. But if we keep the spoon dipped in the pot for too long, the handle also turns warmer. This phenomenon of exchange of heat through a solid material or between two solid materials in contact, is called 'conduction'.

When a gas like air, or a liquid like water, flows over a hot surface, it gets heated, or it gets cooled when flowing over a cooler surface, because an exchange of heat has taken place between the liquid or gas, and that surface. This phenomenon of exchange of heat is called 'convection'.

Solar water heating principles

Let us examine the phenomenon of heating with solar energy. The sun radiates energy in the form of heat and light. The dark coloured surface of an object, when exposed to the sun, absorbs most of the heat and the object gets heated up. As a result, there is a rise in the temperature of the associated material by way of conduction. Since the dark coloured object has attained a higher temperature than the surrounding air, it exchanges heat with the air, by way of convection. Again, as the dark object is exposed to the atmosphere, it exchanges heat with the atmosphere by way of radiation.

If we can control the exchange of heat between the dark coloured object (absorber surface in the collector) and the material that is required to be heated up (water in the collector) by way of conduction or convection, it would be considered as a desirable heat exchange. The devices used for solar heating, try to increase this desirable heat exchange and reduce the undesirable heat loss to air, atmosphere or other materials in contact. The device that is used for this controlled heat exchange and for converting the solar energy into useful heat is called a solar collector.

The solar radiation on earth comes from two sources. One, direct solar radiation, which comes directly from the sun, and other, the diffused solar radiation which is scattered by the atmosphere or is reflected from the surrounding objects in a random form. Some solar heating devices are able to use both the diffused as well as the direct solar radiation, while some are able to use only the direct solar radiation. Solar water heating systems use both.

Solar water heater classification

As the key components in building solar water heaters, solar collectors accept solar radiation, convert it into thermal energy and deliver it to the water in the solar water heating system. Based on the solar collector types, solar water heater systems are classified as flat plate solar water heaters, all-glass vacuum tube heaters and heat pipe vacuum tube heaters.

Flat plate solar water heaters

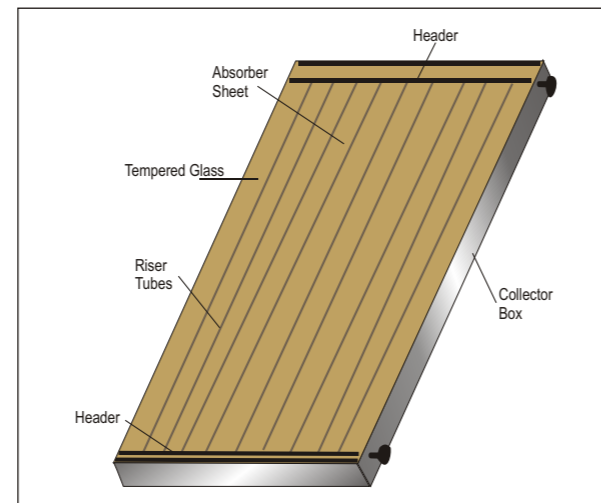

Fig 17: Front view of a flat plate collector

As the name implies, the surface of the solar flat plate collector which is exposed to the sun is in the shape of a flat plate. A flat plate solar collector comprises a transparent cover, an absorber plate, an insulation layer and an outer covering.

Heat collection theory:

After penetrating the transparent cover, the sun's rays are projected on the absorber plate. The absorber plate goes on to absorb solar energy, converts it into heat energy and passes the heat energy to the heat transfer medium inside the tubes. The temperature of the heat transfer medium (in this case, water) rises.

The absorber plate is normally made of copper. In order to better absorb solar energy, the absorber plate is covered with a selective coating. The German TINOX coating absorbs 95% of solar energy and reflects back only 5% of thermal energy.

Significance of the different components of a flat plate collector:

The absorber plate is exposed to the sun and gets heated up by absorbing the solar radiation. Tempered glass is used to prevent the absorber from direct contact with the atmospheric air and loss of heat to the air by way of convection, while allowing the solar radiation to reach the absorber surface. The collector box holds the glass in place. The collector box is insulated from all sides to prevent heat loss due to conduction. The bottom header is used for flow of the cold water into the collector, whereas the top header is used to take away the hot water. The top and the bottom headers are connected by a number of copper tubes. These tubes are called risers.

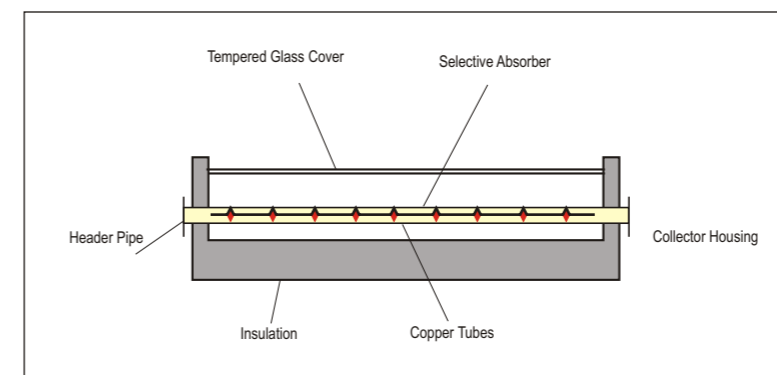

Fig 18: Side view of a flat plate collector

The selection of materials for the solar collector is extremely important to achieve higher efficiency in a solar water heating system. The following points should be kept in mind while selecting the materials for solar water heating systems:

1. Highest possible value for glass transmission coefficient. (Close to 1)
2. Absorber coating with the highest absorption coefficient. (Close to 1)
3. Lowest emission coefficient of the absorber coating.
4. Conduction of heat from the absorber plate to the tubes is governed by the thickness and conductivity of the material used and the contact between the absorber and the riser tubes. Therefore, it is desirable to have the maximum possible contact between the riser tubes and the absorber plate. High conductivity material should be used for this purpose.

The quality of the materials used and the construction methods employed, which determine the life of the collector and its performance, are:

1. Leakage resistance, to avoid seepage of rain water.
2. Corrosion resistance in different environmental conditions.
3. Resistance against ultraviolet radiation.
4. Resistance against cyclic heating and cooling effect.
5. Structural stability and resistance against wind.
6. Proper sealing properties of the gaskets against cyclic heating and cooling effect.
7. Durable fasteners suitable for outdoor conditions.

8. Transparent, tempered glass to withstand natural calamities, monkeys or birds jumping onto it.
9. The design of the collector must be made considering the expansion and contraction of materials due to temperature variation.
10. The riser and the header should be resistant to corrosion and should not react with the chemical content of water. (The quality of water/fluid used determines the compatibility of the tube materials for corrosion resistance.)
11. The capability of the metal used in the riser and header to withstand high temperature and pressure.
12. The capability of the insulation materials to withstand high temperature.

Sub-classification of solar flat plate collectors

Based on number of covers:

Unglazed, single-glazed or double-glazed, depending upon whether there will be no cover, a single transparent cover or two transparent covers with an air gap between the two covers. The two-cover system reduces the loss of heat to the ambient air, compared to a single transparent cover. However it also reduces the solar radiation reaching the absorber due to the transmission loss through two covers. Therefore double-glazed collectors are useful only in some special applications.

Based on type of absorber coating:

As black painted or selectively coated, depending on the use of black absorbing paint or selective coating on the absorber surface.

Based on the material of the absorber:

Copper, aluminium or mild steel are used as absorber materials. Unglazed collectors are made with black plastic materials also. However, each material will have different impact on the efficiency, reliability and durability of the solar water heater.

Evacuated tube solar collectors

There are mainly two types of evacuated tube solar collectors:

1. All-glass vacuum tube collectors
2. Heat pipe type vacuum collectors

1. All-glass vacuum tube collectors:

Looking like long, thermos bottle liners, all-glass vacuum tube collectors comprise glass tubes (outer tubes), a vacuum inter-space and an inner glass tube (inner tube).



Heat collection theory:

Solar energy radiation permeates the outer glass tubes to heat the water in the inner tubes. Since cold water has higher specific gravity and hot water has lower specific gravity, cold water flows downwards and hot water rises upwards in the inner tubes, and this gradually raises the water temperature in the hot water tank.

The black part on the outer walls of the inner tubes is selectively coated and it absorbs solar radiation to convert it into heat. The sun's rays reach the absorber coating through the outer glass tubes. The coating absorbs the visible light and near-infrared rays of the sun's rays, to convert solar energy into heat energy. This raises the water temperature in the inner tubes. A selective absorption coating, made of Al-N/Al, is currently the most widely used coating. This coating is capable of absorbing 94% of solar energy and reflecting back 6%.

A vacuum inter-space between the outer tube and the inner tube reduces the heat loss, preserving the heat and thus promoting thermal collection efficiency.

The construction of all-glass vacuum tubes is fairly simple and the production technology is well established.

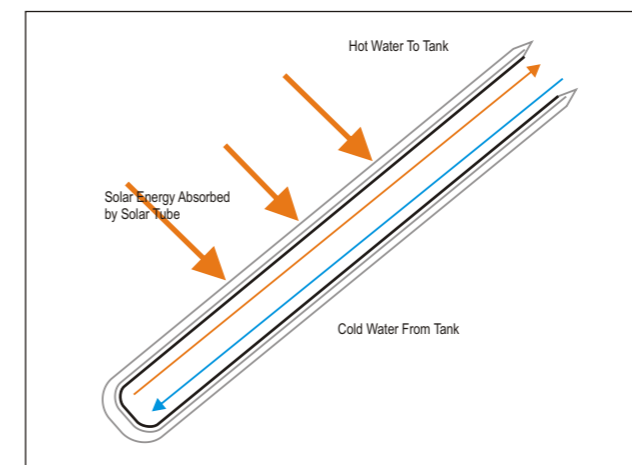

Fig 20: Double glass evacuated tube with inner tube coated and filled with water.

Heat pipe type evacuated tube collectors:

Heat pipe vacuum tube solar heaters consist of glass tubes, heat pipes and metal fins. These are classified into metallic heat absorbing vacuum tube solar heaters (big heat pipes), U-tube solar heaters and others.

Metallic heat absorbing vacuum tube solar water heaters (big heat pipes):

These are also known as big heat pipes, with 100 mm diameters. Such solar water heaters are mainly used as high-grade pressurized water heaters.



Fig 21: Heat pipe type collector

Metallic heat absorbing vacuum tubes have single layer glass (3 mm extra-thick, high borosilicate glass) as outer walls, and a vacuum inside. The absorber plates are made of copper-aluminum compound fins or pure copper fins. The surfaces of the absorber fins are coated with selective absorbing coating. The inside of the heat pipe has a working fluid under vacuum conditions.

The vacuum tubes rely on the metal absorber plates inside the tubes to absorb solar energy and convert them into heat energy. Heat is transferred to the working fluid, which instantly evaporates under the vacuum environment. The hot vapour moves upwards and condenses at the top end and transfers heat to the water in the manifold / tank. The condensed medium flows downwards along the pipe walls. In this gas-liquid cycle, the working medium inside the heat pipes continuously moves the absorbed solar energy to the condensation end for heating water.

The vacuum tubes do not have any water. The metal fins absorb heat. The ends are sealed with a meta- and-glass airtight joint.

U-tubular type vacuum tube solar water heaters:



Fig 22: U-tubular heat pipe

In the U-tube type ETC, U-shaped metal tubes are used inside the all-glass vacuum tubes. Metal fins are attached to the metal tubes and these are in contact with the inner glass tube.

The working medium inside the metal tubes is heated by the solar radiation that is collected by the all-glass vacuum tube and passed via the metal fins. This creates a flow of the medium by convection.

The glass tubes do not come into direct contact with the heated working medium. The U-tubular tubes have water as the working medium. Such heaters have the advantage of all-glass vacuum tubes. Since water is heated in the U-tube pipes, heat may be transferred directly. Since water serves as the working medium, the solar water heaters suffer from such problems as freezing and scale formation in the metal tubes. Therefore, they are normally used in indirect heating systems with forced circulation.

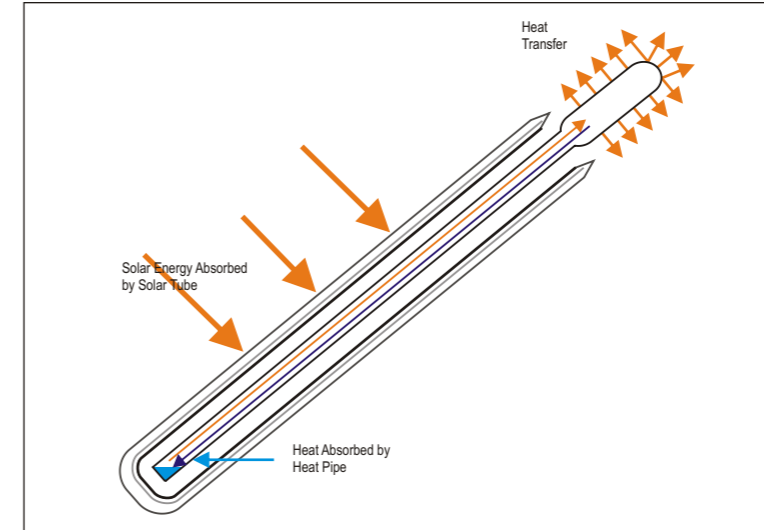

Fig 23: Heat pipe evacuated tube collector (Working principle)

Further classification of solar water heaters

Solar water heaters may also be classified into pressurized and non-pressurized types, according to whether the hot water tanks of the solar water heaters operate under pressure or without pressure. The pressurized type refers to the system in which the water tanks of the solar water heaters can endure the pressure of the water supply and the pressure from the expansion of water when it is heated. Solar collectors of any type may be used in these solar water heaters, with suitable design.

Non-pressurized:

Non-pressurized solar water heaters have the movement of water from the water tanks by gravity, without pressure. The main pipelines of the water tanks are pipes, for supply of cold water into the tank and supply of hot water from the tank. When the solar water heaters are in operation, hot water will flow out of the water outlet pipe under the gravitational head. Water is the medium in the vacuum tubes of non-pressure heaters. While non-pressure based systems are simple in structure and low in cost, these cannot provide pressurized water supply.

Pressurized:

In pressurized solar water heaters, hot water flows from the water tank, under the pressure of cold water supply. During operation, the solar water heaters must have a water inlet valve opened to ensure an uninterrupted supply of water. These systems are easy for operation, but have high production costs.

As per the connection of the water tanks and solar collectors of solar water heaters, solar water heaters may be classified into compact (direct insertion) type and non-compact type.

Compact type (Direct insertion):

Most solar water heaters installed in the country are the compact type, meaning that the solar collectors are directly linked with water tanks.

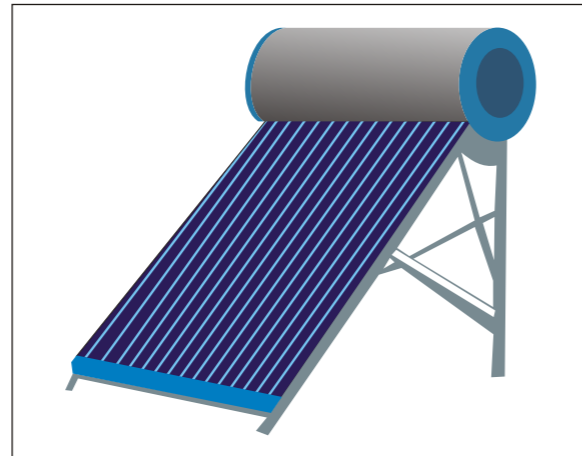

Fig 24: Compact type solar water heater

Non-compact type (Body separation type)

Non-compact type solar water heaters use manifold or piping for the movement of the fluid in the heating system. The solar collectors are separated from the water tanks. They may be installed on house roofs, walls or balconies, for convenient integration of solar collectors and buildings. Water tanks may be installed in all places. In such cases, pumps are normally used for the circulation of the heating medium.

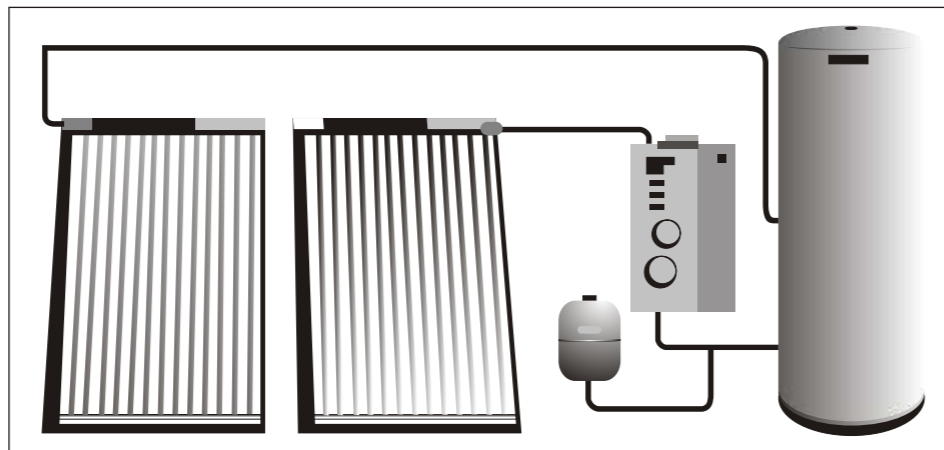

Fig 25: Body separation type solar water heater

Comparative advantages and limitations of different solar collectors

Table 11

	Plate type	All-glass vacuum tube type
Working principle	<ul style="list-style-type: none"> Absorber plate with pure copper or with copper-aluminum compound. Water inside the tubes. Absorbs heat with selectively coated fins. 	<ul style="list-style-type: none"> All-glass tube structure. Water inside the inner glass tubes. Absorbs heat with selective coating on the outer surface of the inner glass tube.
Merits	<ul style="list-style-type: none"> High pressure endurance. Can be exposed to solar radiation even when there is no water inside the tubes. Body separation structure possible and layout of collectors can be made as per building plans. Energy output per unit of installed area of the FPC is higher than of ETC because of larger collector occupancy area. 	<ul style="list-style-type: none"> Simple structure. Lesser heat loss because of vacuum tubes. No corrosion of tubes as it is made of glass.
Demerits	<ul style="list-style-type: none"> No anti-freezing capacity unless used with heat exchanger. Poor heat insulation capacity. No corrosion resistance with certain quality of water. Maximum temperature range is limited. Scale formation in the pipes due to bad water quality. 	<ul style="list-style-type: none"> Cannot be exposed to solar radiation even when there is no water inside the tubes. Gasket is a weak spot for leakage at the tube and tank joints. Scale formation in the pipes due to bad water quality. Temperature can shoot to very high level during summer when water is not in use. Glass tubes are made of thin glass and are prone to breakage. In case of breakage of tubes, the entire ETC system gets drained.
Guarantee period	<ul style="list-style-type: none"> 5 years. (Except for glass breakage.) 	<ul style="list-style-type: none"> 1 year (Except for tube breakage.)
Approximate price	Rs. 18,000 - 24,000	Rs. 12,000 - 15,000
Durability	<ul style="list-style-type: none"> Lasts for 15 years or more without major maintenance. 	<ul style="list-style-type: none"> Lasts for 3 to 5 years without major maintenance.

Economics of solar water heating systems:

A single collector system provides an equivalent of 5 KWH - 6 KWH of heat replacement on an average. It also replaces one to two geyser installations. The saving in terms of capital cost for two geysers may be up to Rs. 10000 - 12000 (including the cost of electricals and plumbing). The solar water heating system may cost Rs. 25000, including the cost of plumbing. Thus, solar water heating systems are expensive by about Rs.15000 for a single collector system. It may save an energy equivalent of 1800 KWh at the maximum and

900 KWh at the minimum per year. At energy cost of Rs. 5/KWh, the saving is Rs. 4500 - Rs. 9000 per year, depending on the usage of hot water. At present, some incentives are available from governments in different states, which provide easy financing and also capital subsidy.

Besides, there is the significant advantage of regular availability of hot water in the morning, when the power availability may be a problem due to high morning peak loads in winter months.

Environmental and other advantages of solar water heating systems:

Each KWh of electricity produced uses 1 kg of coal for production of energy. Besides, with transmission and distribution losses of 20% at the minimum, for each unit of power reaching a household, the effective coal consumption is 1.25 kg. Energy is also spent in transporting coal to the power plants, which may add 0.25 kg equivalent of coal. Thus a saving in coal burning of 1.5 kg is effected by saving one KWh of energy. The smallest solar water heating system will have a saving of equivalent of coal burning of 1350 to 2700 kg per year of use.

Each unit of power produced, uses 3 litres of water by evaporation, for cooling purposes, in a power plant. A single collector system avoids a loss of 2700 to 5400 liters of water per year.

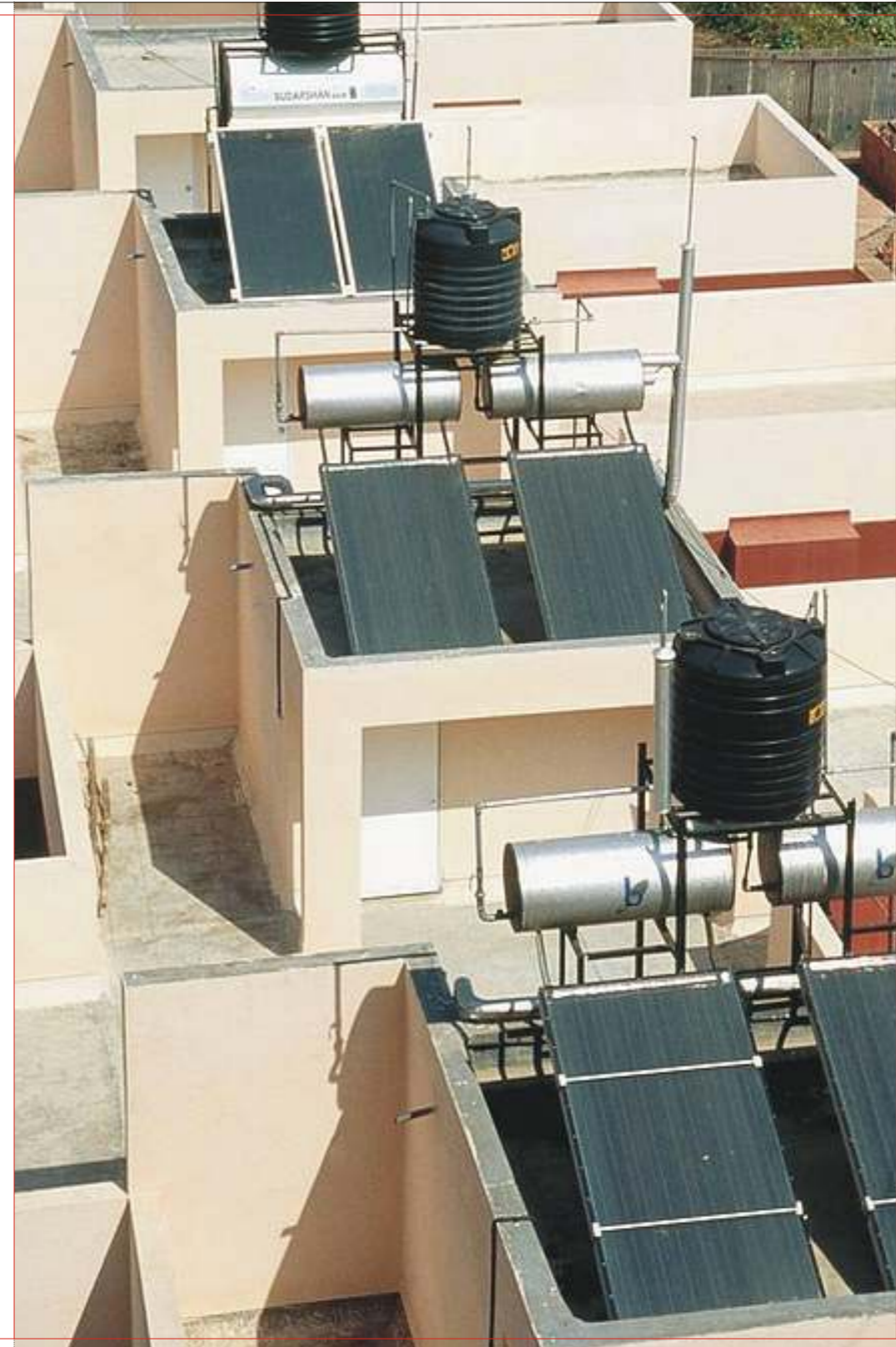

Annexure B

SWH Applications

Water heating systems in high rise residential buildings

Solar water heating systems are being installed on multistorey buildings with a large number of apartments. There are different ways of installing these solar water heating systems. The system shown below has been installed on the terrace of the a 20-storeyed highrise building of Reserve Bank of India in Lower Parel, Mumbai, with a capacity of 10,000 litres /day of hot water. The system has a supply-and-return piping to ensure hot water availability round-the-clock.



Name & Address		Key Statistics
Sun Palazzo, Lower Parel, Mumbai.	Capacity: No. of floors: Completion: Total cost: System: Electricity savings	10,000 LPD system 20 1998 Rs. Closed loop forced circulation 400 Kwh per day

Water heating system in apartment blocks

A number of systems of smaller capacity were installed on the terrace of the multistorey building with a large number of apartments. Each system is installed to meet the capacity requirement of apartments connected to a common pipe shaft. The system shown in the picture has been installed on Vikas Palms in Thane. The total capacity of all the systems put together is 16200 liters per day for 54 apartments.



Name & Address		Key Statistics
Vikas Palms, Thane	Capacity: No. of floors: Completion: Total cost: System: Electricity savings	16,200 LPD system G+17 Rs. Thermo-siphon type

Water heating systems in hotels

Solar water heating systems are an effective solution for the hot water requirements in hotels. A number of hotels have already installed solar water heating systems and saved electricity considerably. In the following example of J.P. Siddhartha Hotel, the payback was realized within two years of time.



Name & Address	Key Statistics	
J. P. Siddhartha Hotel, Delhi	Capacity:	3500 LPD system
	Completion:	2008
	Total cost:	Rs. 490000.00
	System:	Bailer feed
	Electricity savings	175 Kwh per day

More pictures of SWH applications in hotels



Name & Address	Key Statistics	
Leo Inn, Jalandhar	Capacity:	6000 LPD system
	Completion:	2002
	Total cost:	Rs.
	System:	Direct
	Electricity savings	Kwh per day

Water heating system in hostels

Solar water heaters can also be a solution for hot water requirements in hostels . The following is an example of Infosys Hostel in Mysore, which was developed by M/s Shobha Developers, with a capacity of 1,77,000 liters per day.



Name & Address		Key Statistics
Infosys Hostel, Mysore	Capacity:	16,000 LPD system
	Pool size:	600,000 liters
	Completion:	2007
	Total cost	Rs. 30 lacs
	System:	Pressurized recirculation
	Electricity savings	1550 Kwh per day

Water heating system in hostels

Solar heating systems can be used efficiently for swimming pool heating as well. The following is an example of swimming pool heating in the Golf Club of Chandigarh, which has a capacity of 6 lacs liters. The project cost was Rs. 30 lacs, with per day electricity savings of 1550 units. Even if the swimming pool heating is operated for 6 months a year, the payback would be realized in 2.5 years.



Name & Address		Key Statistics
Golf Club, Chandigarh	Capacity:	16,000 LPD system
	Pool size:	600,000 liters
	Completion:	2007
	Total cost	Rs. 30 lacs
	System:	Pressurized recirculation
	Electricity savings	1550 Kwh per day

Water heating system in textile mills

Solar water heating systems are a solution for low and medium pressure process heating and boiler pre-heating in industrial applications. Textiles is one such industry, which requires hot water for dyeing purposes. The following is an example of a 25 Kcal per day system in the Chelsea Jeans Mills in Haryana, which helped the company to save 271 liters of diesel per day. Considering an average price of Rs. 30 per liter of diesel, the payback to the company would come in approximately three years of time.



25 lakh Kcal per day system at Chelsea, Manesar, Haryana

Name & Address		Key Statistics
Chelsea Mills, Manesar, Haryana	No. of collectors	410 nos.
	Tank capacity:	10,000 liters
	System size:	50,000 liters
	Completion:	2006
	Total cost	Rs. 46.50 lacs
	System:	Pressurized re-circulation
	Energy displaced	25 lakh Kcal per day
	Fuel savings	271 liters diesel per day

Water heating system in dairy applications



Solar water heating system at the MILMA Dairy, Kerala

Name & Address		Key Statistics
MILMA Dairy, Kannur, Pallakad, Kerala	No. of collectors	720 nos.
	System size:	60,000 liters
	Completion:	2003
	Total cost	Rs. 46.50 lacs
	Application	Pasteurization of milk
	System:	Pressurized recirculation
	Fuel savings:	250 liters diesel per day

Water heating system in leather industry



Solar water heating system at Leo Leather Industry, Jalandhar

Name & Address		Key Statistics
Leo Leather Industry, Jalandhar, Punjab	No. of collectors	150 nos.
	System size:	15,000 liters
	Completion:	1998
	Total cost	Rs.
	Application	Chemical mixing, drying
	System:	Boiler feed

Water heating system in metal plating



12 lakh Kcal per day system for nickle bath at Kangaroo Industry, Ludhiana

Name & Address		Key Statistics
Kangaroo India Limited, Ludhiana	No. of collectors	220 nos.
	Tank Size:	5000 liters
	System size:	60,000 liters
	Completion:	2006
	Total cost	Rs. 30 lacs
	Application	Nickel bath
	System:	Pressurized recirculation
	Fuel savings:	110 liters diesel per day

Water heating system in food processing



Name & Address		Key Statistics
Kwality Walls Ice Cream, Delhi	No. of collectors	60 nos.
	System size:	6,000 liters
	Completion:	2000
	Total cost	Rs.
	Application	Cleaning and making sugar solution
	System:	Thermo-siphon type
	Energy savings	240 Kwh per day

First Edition: 2010

This handbook is not for sale and is available free of cost to the end users. Comments and suggestions are welcome before printing a revised edition. Please send your comments and suggestions to:

Project Management Unit
UNDP / GEF GSWH PROJECT
Ministry of New and Renewable Energy,
Block No. 14, CGO Complex, Lodhi Road,
New Delhi - 110 003.
Tel - 001 - 24361152.

At International Copper Promotion Council (India), the environment has always taken precedence. Therefore, we have always preferred employing 'eco-friendly' materials, wherever possible. Shiro Echo paper, made from post-consumer waste, is a purely ecological product. Even during its manufacturing, care is taken to see that only renewable energy sources are used in order to reduce CO₂ emissions.

Second Edition : 2012

This second edition has been arranged due to welcome response from connected Professionals. Some corrections have been made to the previous edition based on feedback from some of the users. In case of any further feedback, please do write to us :

INTERNATIONAL COPPER PROMOTION COUNCIL (INDIA)